

Operation Manual and Parts Book

Wessex AF120 & AFC120 Trailed Flail Mowers

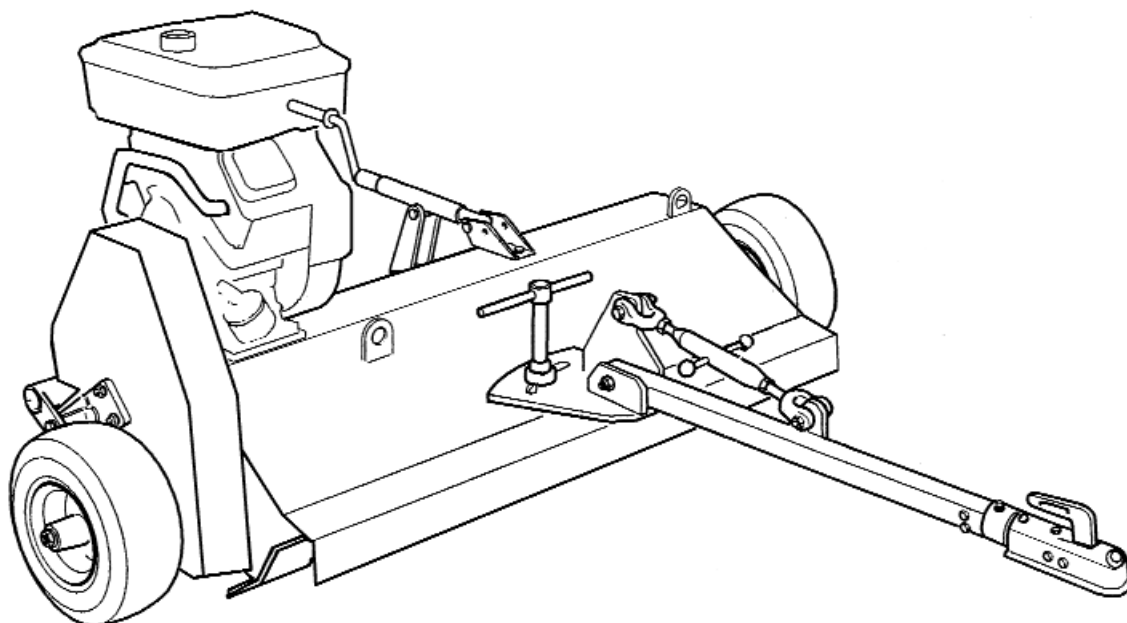

Product Code: L2002

CONTENTS

Welcome to your new Wessex Product	1
Safety Decals	2, 3
Important Safety Warnings	4
Important ATV Safety Warnings	5, 6
Warranty	7
Setting up your Mower	8
Using your Wessex Mower / 4 Wheel Version	8
Belt Adjustment	9
Maintenance / Belt Adjustment / Lubrication / Flail Blades	10
Troubleshooting / Winter Storage	11
Parts Illustration - AF & AFC 120 - - Mainframe Assembly	12
Parts List - AF & AFC 120 - Mainframe Assembly	13
Parts Illustration - AF120 Side Wheel Assembly	14
Parts List - AF120 Side Wheel Assembly	15
Parts Illustration - AF & AFC 120 Rear Wheel Assembly	16
Parts List - AF & AFC 120 Rear Wheel Assembly	17
Parts Illustration - AF & AFC 120 Four Wheel Assembly	18
Parts List - AF & AFC 120 Four Wheel Assembly	19
Parts Illustration - AFC120 Side Wheel Assembly	20
Parts List - AFC120 Side Wheel Assembly	21
Parts Illustration - Drive Shaft Assembly (Centre Mount)	22
Parts List - Drive Shaft Assembly (Centre Mount)	23
Parts Illustration -Manual Engagement Assembly	24
Parts List - Manual Engagement Assembly	25
Parts Illustration / Parts List - Control Arm Option	26
Illustration -AF120 Belt Retainer Positioning	27
Illustration - Adjusting Screw Mount / Pivot Position for Adjusting Screw Assembly	28
CE Certificate	29

WELCOME TO YOUR NEW WESSEX PRODUCT

Thank you for purchasing a Wessex product. As a Wessex customer, you now number among the most important people of our business and we will endeavour to give you the best service available through our dealer network.

Please read this Manual carefully and familiarise yourself and other persons that will be using the machine with its contents, to ensure the optimum performance and working life of your machine. It is advisable that a copy of this Manual is kept in the workshop and one copy with the machine. Further copies are available through your dealer.

On delivery, your dealer should go through the workings of the machine with you, explaining the setting up procedures, all of which are contained in this manual for further reference. The Warranty Registration Form must also be completed and returned to us **within 7 days of delivery** in order to validate the Warranty.

**PLEASE READ THE FOLLOWING PAGES CAREFULLY BEFORE USING YOUR MACHINE
AND KEEP THIS MANUAL IN A SAFE PLACE.**



**THIS SAFETY SYMBOL IS TO ALERT OPERATORS OF A HAZARD
THAT MAY RESULT IN INJURY.
ALWAYS FOLLOW INSTRUCTIONS CAREFULLY**

SAFETY DECALS



- GB **ATTENTION** Description of pictograms.
 F **ATTENTION** Description des pictogrammes.
 D **VORSICH** Beschreibung der piktogramme.

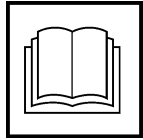

- GB Read Operating manual before use.
 F Lisez Manual D'Opération avant l'utilisation.
 D Vor der Benutzung, Betriebshandbuch lesen.



- GB Ear defenders must be worn.
 F Défenseurs des oreilles doivent être portés.
 D Gehörschutz getragen werden.



- GB Never remove guards or attempt adjustment until rotor has stopped.
 F Ne retirez jamais les gardes ou d'ajustement tentative jusqu'à ce que toutes les pièces mobiles ont été interrompus.
 D Schutzvorrichtung niemals abnehmen oder einstellung versuchen, bevore der rotor abstellt.



- GB Bystanders must be at least 20 metres from machine range of action.
 F Des spectateurs doivent s'écarter au moins 20 mètres du rayon d'action de la machine.
 D Umstehenden müssen sich mindestens 20 meter vom maschinenbetriebsraum entfernen.



- GB Stand clear. Flying objects possible.
 F S'écarter! Possibilité d'objets volants.
 D Zurückbleiben! Herumfliegende objekte möglich



- GB Lift Machine before turning
 F Levez la machine avant de la tourner
 D Maschine aufheben, bevor man sie umdreht.



- GB Examine blades regularly. The operator is responsible for machine damage caused by unbalanced rotors.
 F Examinez des lames régulièrement. L'opérateur est responsable des dommages à la machine provoqués par des rotors mal équilibrés
 D Klingen regelmäßig kontrollieren. Der abeiter ist an den durch unausgewogenen rotoren maschinenschäden verantwortlich.



- GB Keep hands and feet clear
 F Garder les mains et les pieds.
 D Halten Sie Ihre Hände und Füße.

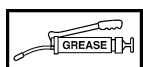

- GB Grease points
 F Les points de graissage
 D Grease Punkte.

SAFETY DECALS



- GB Lifting Point
- F Point de levage
- D Anschlagpunkt



- GB It is the operators responsibility to ensure that the machine is compatible with the loading capacity of the towing vehicle.
- F Il est de la responsabilité des opérateurs afin de s'assurer que la machine est compatible avec la capacité de chargement du véhicule tracteur.
- D Es ist den Betreibern dafür zu sorgen, dass die Maschine mit der Belastbarkeit des Zugfahrzeugs ist.



- GB Never carry passengers on implements unless designed to do so.
- F Ne jamais transporter des passagers sur instruments sauf s'ils sont conçus pour le faire.
- D Niemals Passagiere implementiert, es sei denn ausgelegt, dies zu tun.



- GB ATTENTION: Engage Slowly.
- F ATTENTION: Engagez Lentement.
- D VORSICH: Einschalten Langsam.

IMPORTANT SAFETY WARNINGS



Wessex machines are guarded for your protection, but you must always observe certain elementary precautions. Machines are potentially **dangerous** and should be used with the greatest respect and **ALL OPERATORS MUST** read this manual and be aware of all safety precautions.

1. **NEVER** attempt any adjustment whatsoever, unless the machine is **COMPLETELY** at a standstill.
2. **NEVER** attempt to clear any obstructions around the mower unless the machine is **COMPLETELY** at a standstill.
3. **NEVER** remove belt guards unless the machine is **COMPLETELY** at a standstill.
4. **NEVER** remove safety guards which are provided for your protection.
5. **NEVER** operate the mower with people behind, keep everybody (especially children and animals) at a safe distance, **minimum 20 metres**.
6. Stand well back from the machine when cutters are spinning.
7. Regularly inspect the **BLADES AND FIXING BOLTS** to ensure that they are in tip-top condition. Replace blades **IMMEDIATELY** if any signs of fracture or excess wear becomes apparent. Serious damage, which is excluded from our warranty conditions, may result from using your mower with an unbalanced rotor. When replacing blades, always fit new mounting bolts and nuts to ensure that the rotor is balanced and running smoothly.

HEALTH AND SAFETY - Noise at Work Regulations

READING AT THE OPERATORS EAR

Wessex AF Flail mower: Approximately 97.5 D.B.A

Depending on conditions and material being cut, this reading may alter, it is therefore advisable for users to do their own assessment.



In compliance with the above regulations, Ear Protectors must be worn when operating machinery.

IMPORTANT ATV SAFETY WARNINGS

READ THE FOLLOWING CAREFULLY

IMPORTANT SAFETY INSTRUCTIONS ON COUPLING IMPLEMENTS AND ATTACHMENTS TO ATV'S



TRAINING

- It is most essential that all operators of ATV's are trained by a certified training organisation.
- It is strictly forbidden that any person under 16 years of age should ride an ATV.
- Any person 17 years of age must have had training before towing a trailer with an ATV.
- Contact your local HSE office for approved training courses.

BODY PROTECTION

- Remember that when riding on an ATV the only form of protection that you have is what you wear. **ALWAYS** wear a helmet, eye protection and suitable robust clothing.
- Never operate an ATV or attachments while under the influence of alcohol or non-prescription drugs.
- Contact your doctor before operation of an ATV or attachments while under the influence of any prescription drugs.

ATV MANUAL

- Before coupling any implement to your ATV refer to your ATV handbook.

STABILITY

- When using equipment coupled to an ATV it is very important to remember that the handling characteristics of your ATV will change dramatically, whether the additional load is placed on the front or rear rack or trailed on the towing ball hitch.

WEIGHT CAPACITY

- Always ensure that the implement or attachment that you are coupling to the ATV is within the ATV's drawbar loading or weight carrying capacity. Refer to the ATV manufacturer's handbook to obtain information on the specific capacities.
- It is most important that you know the weight of your load, especially when on slopes or hillsides.
- As a guide, on level ground with an unbraked implement, the weight of the implement should be approximately no more than twice the unladen weight of the ATV. This should be reduced on sloping, uneven or rough ground.

WEIGHT TRANSFER

- Always take great care when towing loads which may be subject to weight transfer e.g. liquids or livestock, especially on hillsides and slopes.
- Always restrict the movement of animals or rolling objects in a trailer.

IMPORTANT ATV SAFETY WARNINGS

TOWING

- Never tow loads larger or heavier than recommended for your ATV. (See ATV hand book).
- Never tow or turn across a slope.
- Never tow down a steep slope with a large or heavy load.
- When towing heavy loads there is a significant risk of jack-knifing or overturning.

ROUGH TERRAIN

- Always take care when operating implements on rough terrain or uneven ground.
- Take special care when operating on slippery surfaces especially hill sides or slopes.
- Take extra care when towing on hillsides, slopes or rough terrain.

OPERATING ON ROADS

- Implements are not designed for travelling distances on roads but when crossing or going short road distances always travel slowly and do not exceed 20 KPH.
- Make sure that your equipment complies with Road Vehicle Lighting Regulations.
- Ensure that you have the correct insurance cover and comply with all relevant laws.

LOAD SECURITY

- Always secure your load firmly with ratchet straps.
- Make sure that your load is evenly; distributed.
- Never stack a high load, high loads increase the risk of overturning.

PASSENGERS

- Never carry passengers on any kind of implement or attachment, especially children.

MAINTENANCE

- Service your ATV and attachments as per the manufacturer's handbook. Regular servicing of your ATV will ensure that it will steer, stop and handle to its best ability and your attachment will operate as safely and effectively as possible. Regular servicing helps ensure the longest possible working life for your equipment.

EQUIPMENT SAFETY INSPECTION

- Check tyre pressure, incorrect tyre pressure can seriously affect the handling of your ATV. (See Operators handbook).
- Maintain your equipment regularly to keep it in safe working order.

ROUTE / RISK ASSESSMENT

- Assess and plan the route that you intend to travel to avoid any type of hazards i.e. rocks, boulders, ditches, hidden fences or wire, pot holes, low hanging branches or any other type of hazard.
- Where possible stay with a routine route to avoid hazards.
- The risk may change in wet or wintery conditions, avoid slopes where possible.

WARRANTY

Your Wessex product or equipment is warranted free from defect in workmanship or manufacture for one year from date of purchase. Any parts which appear to us to be defective, either in material or workmanship shall be replaced or repaired at no cost to the purchaser, subject to the following conditions:

1. The registration card enclosed with this booklet must be returned to us within seven days of purchase.
2. Any failure in the machine should be reported in the first instance immediately to your dealer, who will act on your behalf to resolve the matter to your satisfaction.
3. The defective parts will be returned by your dealer to us, accompanied by a full statement describing the failure and the circumstances and conditions in which the failure occurred.
4. The following are specifically excluded from our terms of warranty:
 - a) Fair wear and tear, especially to belts, brushes, blades and spinners.
 - b) Damage to blades or brushes caused through incorrect positioning of the rotor (see instructions).
 - c) Damage caused by neglect or lack of lubrication.
 - d) Damage caused by misuse or abuse.
 - e) Damage caused whilst the machine is in transit.
 - f) Damage caused to the frame of the machine by running the machine with unbalanced rotors, blades or spinners.
 - g) Damage caused to the machine by use with loose nuts, bolts, screws or any other type of fittings.
5. The warranty is for the benefit of the first user only.
6. Wessex International decisions will be final and binding.

Note:

It is recommended that every machine is inspected after one hour of operation to check that all nuts, bolts, screws or any other types of fixings are tight and any loose fixings or components should be rectified as appropriate.

Further inspections should be carried out at regular intervals thereafter.

SETTING UP YOUR MOWER

1. Reverse your towing vehicle up to your machine, and connect to the ball hitch. Ensure that it is locked in position prior to use.
2. Secure the engine cut-off switch to the rear carrier, within easy reach of the operator.
3. Ensure that the rotor is disengaged, and stationary, before using the adjustment handle to adjust the cutting height.
4. Adjust the rear roller to suit conditions. Set the roller down for large volumes of cut material.
5. In order to obtain full cutting height adjustment, the adjustment handle(s) must be in the correct position on the adjusting screw mount see Plate 10 (page 30).

USING YOUR WESSEX MOWER

1. Centrifugal Clutch version - The engine on your mower can be started with the throttle set at either the high or low revs setting, but always ensure that the revs are immediately adjusted so that the clutch is either completely engaged or disengaged. Running the machine with the clutch partially engaged will drastically reduce the life of the clutch.
2. Manual Clutch version - Always start the engine with the clutch disengaged.
IMPORTANT - To commence cutting, engage the clutch slowly!
3. Suitable forward speed will be determined by the amount, type, and condition of material to be cut. In very difficult conditions, better results will be obtained by making two passes, and adjusting cutting height accordingly.
4. Cutting height is adjusted by turning the adjustment handle in the relevant direction.

4 WHEEL VERSION

1. Both front and rear wheels should be adjusted for cutting height, to keep the machine level.
2. When towing between jobs, it is advisable to adjust cut height to maximum, for smooth running of front (swivel) wheels.

BELT ADJUSTMENT

1. Remove Belt Cover.

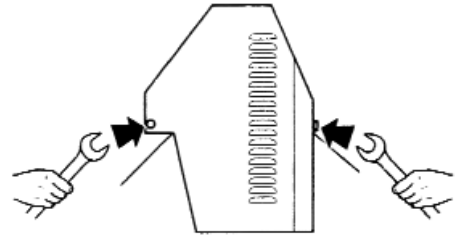

2. Loosen Jockey Pulley Bracket clamping bolt.

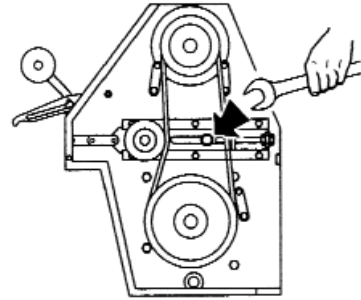

3. Tighten belts using adjusting screw and lock off.

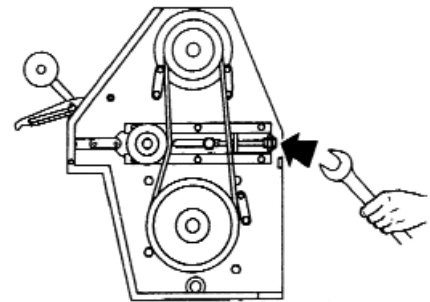

4. Retighten clamp bolt.

5. Replace Belt Cover.

NOTES

1. For Manual version, the clutch lever should be in the drive position for belt adjustment.
2. The belts should be free to move 10mm under moderate thumb pressure.
3. The three belt retainers, should be positioned as shown on Plate 9 (page 29).
4. Check belt tension after 1 hours use, as new belts often slacken while seating in pulleys.
5. For Centrifugal Clutch machines, it is strongly advised not to put the machine to heavy work for the first 5 hours of use, as this can cause the clutch to overheat, consequently reducing its useful life.

MAINTENANCE

- **IMPORTANT!** Check that all fastening sets (bolts and nuts) are tight after the first hour of operation.

LUBRICATION

DAILY (8-10 working hours)

- Grease Main Rotor bearings (x2).
- Grease Roller bearings (x2).
- Grease Wheel bearings (x2).

FLAIL BLADES

- The condition of the flail blades should be inspected daily. Damaged flail blades cause imbalance in the rotor and in turn, will cause serious damage to the mower, **which is specifically excluded from our Warranty Conditions.**
- If the mower begins to vibrate, stop work immediately and investigate. Almost certainly the cause will be damaged flail blades, or foreign objects around the flail rotor.

FLAIL BLADES - CHANGING

- When fitting new flail blades, unhitch the mower from the tractor/ATV and lift the mower up enough to access the blades, (preferably with a hoist or mechanical lifting equipment). Remove the damaged flail blades and replace.
- It is important that the rotor remains balanced. Always fit new bolts and nuts when replacing the flails and preferably fit a full set. If only one or two flails are being replaced, they should be fitted opposite to each other on the rotor, to keep the rotor balanced.

TROUBLESHOOTING

FAULT	CAUSE	REMEDY
Leaving wheel track uncut	1. Forward speed too fast 2. Cutting height too high	Reduce forward speed Lower cutting height
Bad quality of cut	1. Forward speed too fast 2. Excessive blade wear 3. Belts slipping	Reduce forward speed Replace blades Tighten belts
Narrow strip uncut	1. Possibly missing or broken blade	Inspect blades and replace as necessary
Excessive vibration	1. Damaged or missing blades 2. Bent flail rotor 3. Main rotor bearing failed 4. Loose part	Inspect and replace blades Inspect rotor Inspect bearing, replace if damaged Check all nuts and bolts are tight
Excessive scalping	1. Cutting height too low	Raise cutting height.

WINTER STORAGE

Before winter storage, the AF Flail Mower should be thoroughly inspected:-

- Repair or replace any worn or broken parts.
- Take special care to look at the flail blades, rotor and the bearings.
- Remove the belts and ensure that the rotor is free-spinning.
- Make sure that the belts are in good condition before re-fitting.
- Thoroughly wash the machine to remove all oil, grease, debris and materials.
- Grease up all grease points before storage to avoid any corrosion.
- Check or change engine oil depending on hours of use.

PARTS ILLUSTRATION - AF & AFC120 MAINFRAME ASSEMBLY

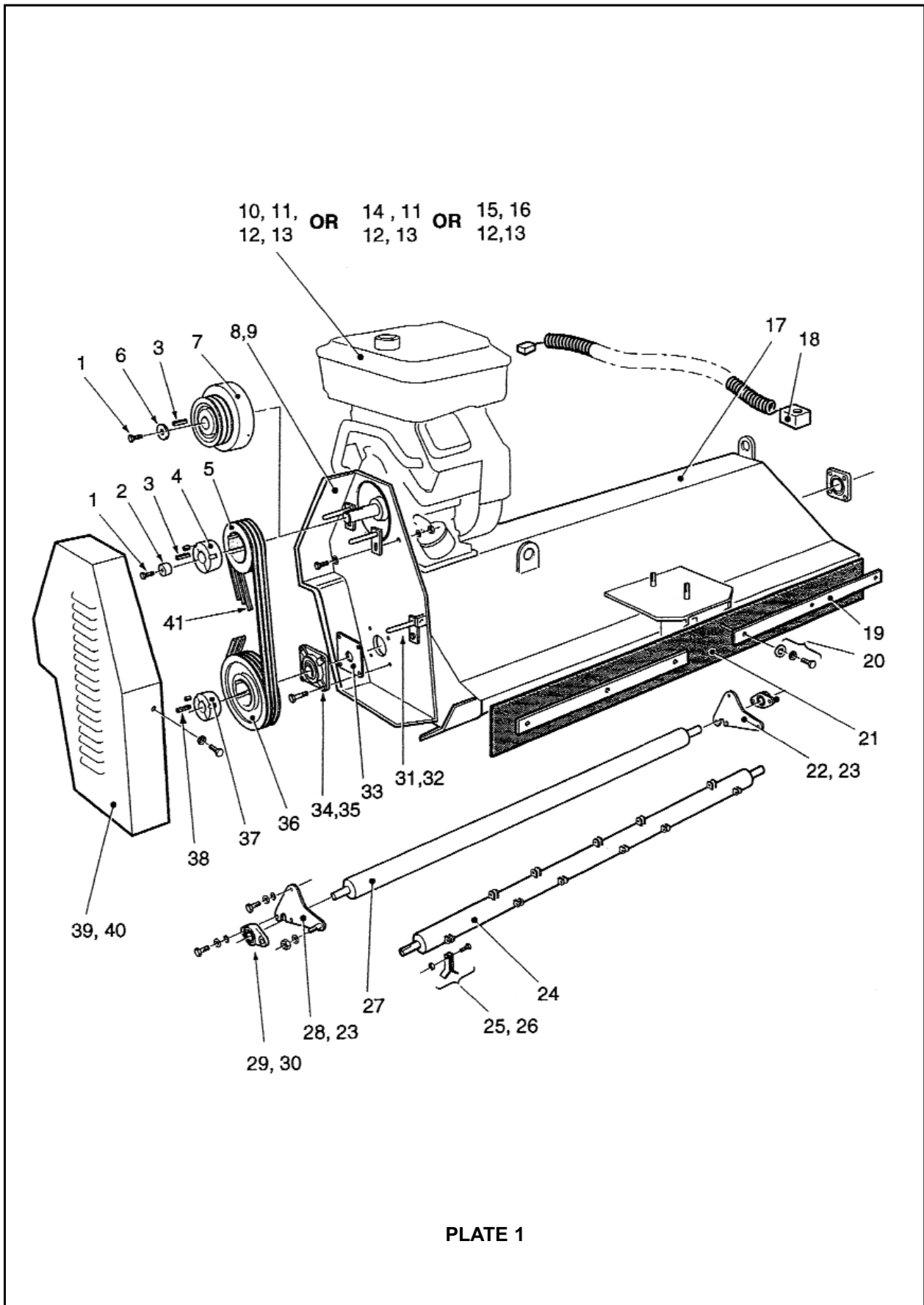

PARTS LIST AF & AFC120 MAINFRAME ASSEMBLY - PLATE 1

Item No.	Part No.	Description	Qty. per Machine
1	WX-2903	Fastening Set	1
2	WX-9666	Shaft Spacer	1
3	WX-1347	Key	1
4	WX-7262	Taper Lock	1
5	WX-8062	Engine Pulley	1
6	WX-1520	Special Washer	1
7	WX-7462	Centrifugal Clutch	1
8	WX-10277	Fixed Guard	1
9	WX-0103	Fastening Set	1
10	WX-0760	16 HP Engine	1
11	WX-1603	Fastening Set	1
12	WX-10457	Engine Mounting Plate	1
13	WX-1303	Fastening Set	1
14	WX-1860	18 HP Engine	1
15	WX-1060	13 HP Engine	1
16	WX-2803	Fastening Set	1
17	WX-8479	Mainframe	1
18	WX-2360	Cut-out Switch Assembly	1
19	WX-5176	Apron Clamp	2
20	WX-2003	Fastening Set	1
21	WX-9478	Front Apron	1
22	WX-1955	Left Hand Roller Bracket	1
23	WX-0303	Fastening Set	2
24	WX-7766	Rotor	1
25	WX-8270	Flail	32
26	WX-6702	Fastening Set	32
27	WX-1655	Roller	1
28	WX-1755	Right Hand Roller Bracket	1
29	WX-0841	Bearing	2
30	WX-1703	Fastening Set	2
31	WX-4858	Belt Retainer	3
32	WX-1103	Fastening Set	3
33	WX-9566	Bearing Shield	2
34	WX-0941	Bearing	2
35	WX-1803	Fastening Set	2
36	WX-7162	Rotor Pulley	1
37	WX-5962	Taper Lock	1
38	WX-0147	Key	1
39	WX-10377	Belt Cover	1
40	WX-0203	Fastening Set	1
41	WX-3934	Drive Belt	3

PARTS ILLUSTRATION - AF120 SIDE WHEEL ASSEMBLY

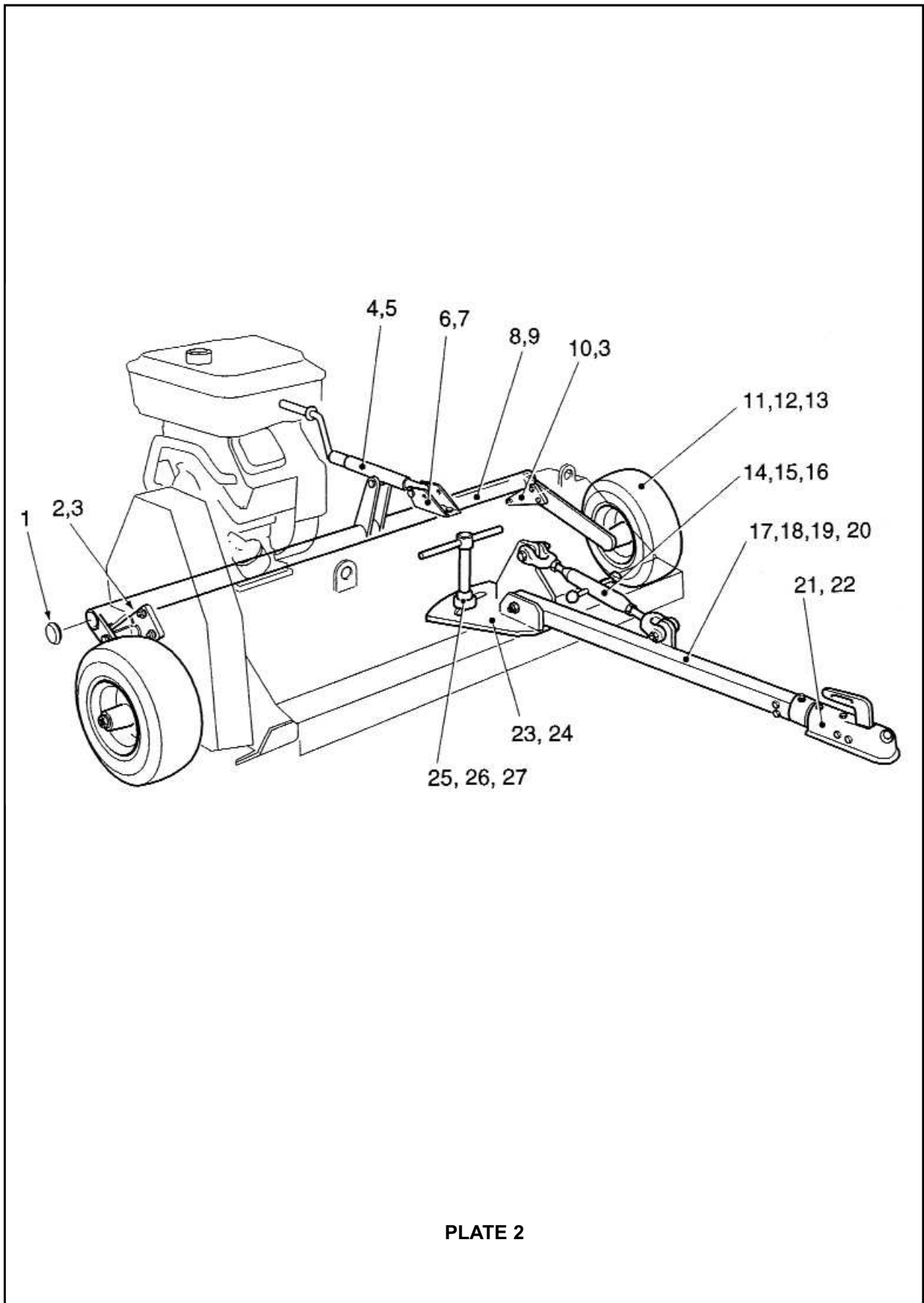

PARTS LIST - AF120 SIDE WHEEL ASSEMBLY - PLATE 2

Item No.	Part No.	Description	Qty. per Machine
1	WX-9053A	Plastic Cap	2
2	WX-11451	Right Hand Wheel Mounting Bracket	1
3	WX-2203	Fastening Set	2
4	WX-13380	Adjusting Screw Assembly	1
5	WX-0603	Fastening Set	1
6	WX-11251	Adjusting Screw Mount	1
7	WX-0403	Fastening Set	1
8	WX-9053	Wheel Mounting	1
9	WX-2103	Fastening Set	1
10	WX-11351	Left Hand Wheel Mounting Bracket	1
11	WX-1352	Wheel	2
12	WX-1538	Wheel Bearing Inner	2
13	WX-1638	Wheel Bearing Outer	2
14	WX-2029	Drawbar Adjuster	1
15	WX-1129	Adjuster Bar	1
16	WX-1129A	Ball Knob	2
17	WX-12880	Drawbar	1
18	WX-4503	Fastening Set	1
19	WX-12156	Tow Hitch Swivel Bar	1
20	WX-1403	Fastening Set	1
21	WX-2356	Tow Hitch	1
22	WX-1503	Fastening Set	1
23	WX-12980	Drawbar Mounting Bracket	1
24	WX-1203	Fastening Set	1
25	WX-5228	Pillar	1
26	WX-5228A	Tommy Bar	1
27	WX-3325	Disc Spring	1

PARTS ILLUSTRATION - AF & AFC120 REAR WHEEL ASSEMBLY

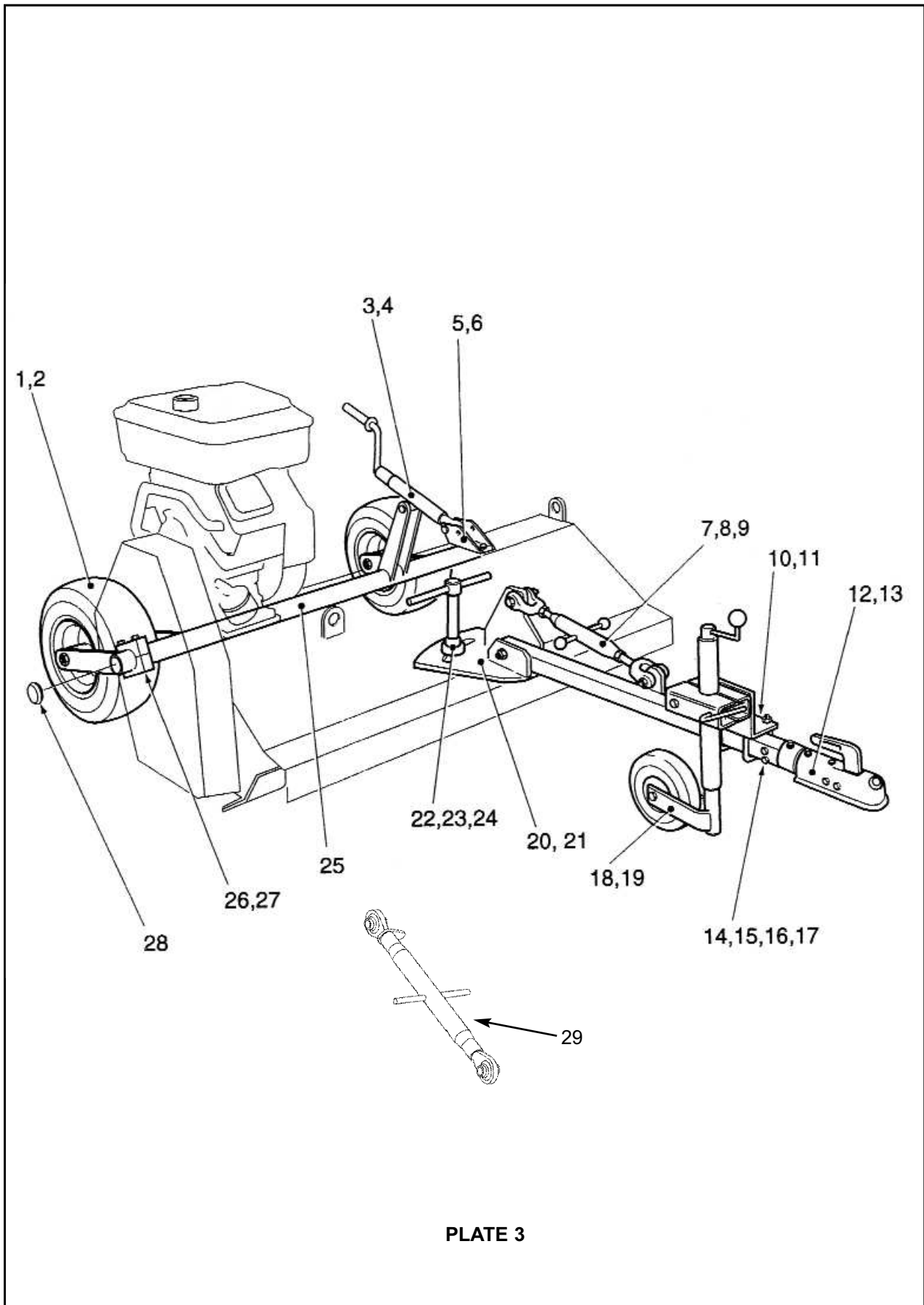

PARTS LIST - AF & AFC120 REAR WHEEL ASSEMBLY - PLATE 3

Item No.	Part No.	Description	Qty. per Machine
1	WX-3152	Wheel	2
2	WX-2503	Fastening Set	2
3	WX-13380	Adjusting Screw Assembly	1
4	WX-0503	Fastening Set	1
5	WX-11251	Adjusting Screw Mount	1
6	WX-0403	Fastening Set	1
7	WX-2029	Drawbar Adjuster	1
8	WX-1129	Adjuster Bar	1
9	WX-1129A	Ball Knob	2
10	WX-11056	Jack Bracket	1
11	WX-7002	'U' Bolt	2
12	WX-12156	Tow Hitch	1
13	WX-1503	Fastening Set	1
14	WX-18280	Drawbar	1
15	WX-4503	Fastening Set	1
16	WX-2356	Tow Hitch Swivel Bar	1
17	WX-1403	Fastening Set	1
18	WX-10956	Jockey Wheel Assembly	1
19	WX-2303	Fastening Set	1
20	WX-18080	Drawbar Mounting Bracket	1
21	WX-1203	Fastening Set	1
22	WX-5228	Pillar	1
23	WX-5228A	Tommy Bar	1
24	WX-3325	Disc Spring	1
25	WX-8753	Rear Wheel Mounting	1
26	WX-11551	Wheel Mounting Support	2
27	WX-2403	Fastening Set	2
28	WX-8853A	Plastic Cap	2
29	WX-2329	Drawbar Adjuster	1
N/S	WX-6628	Drawbar Spacer	4

PARTS ILLUSTRATION - AF & AFC120 FOUR WHEEL ASSEMBLY

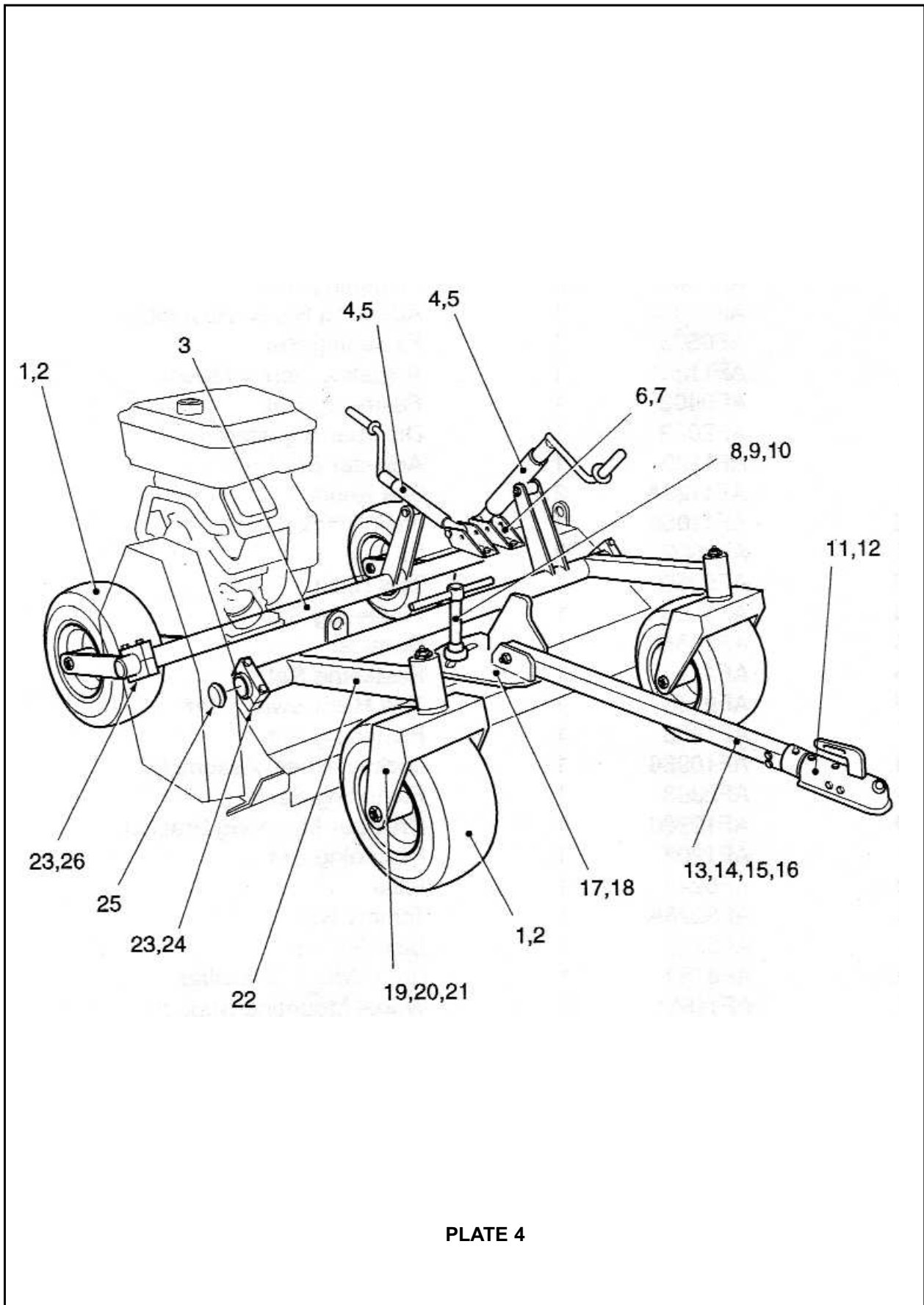
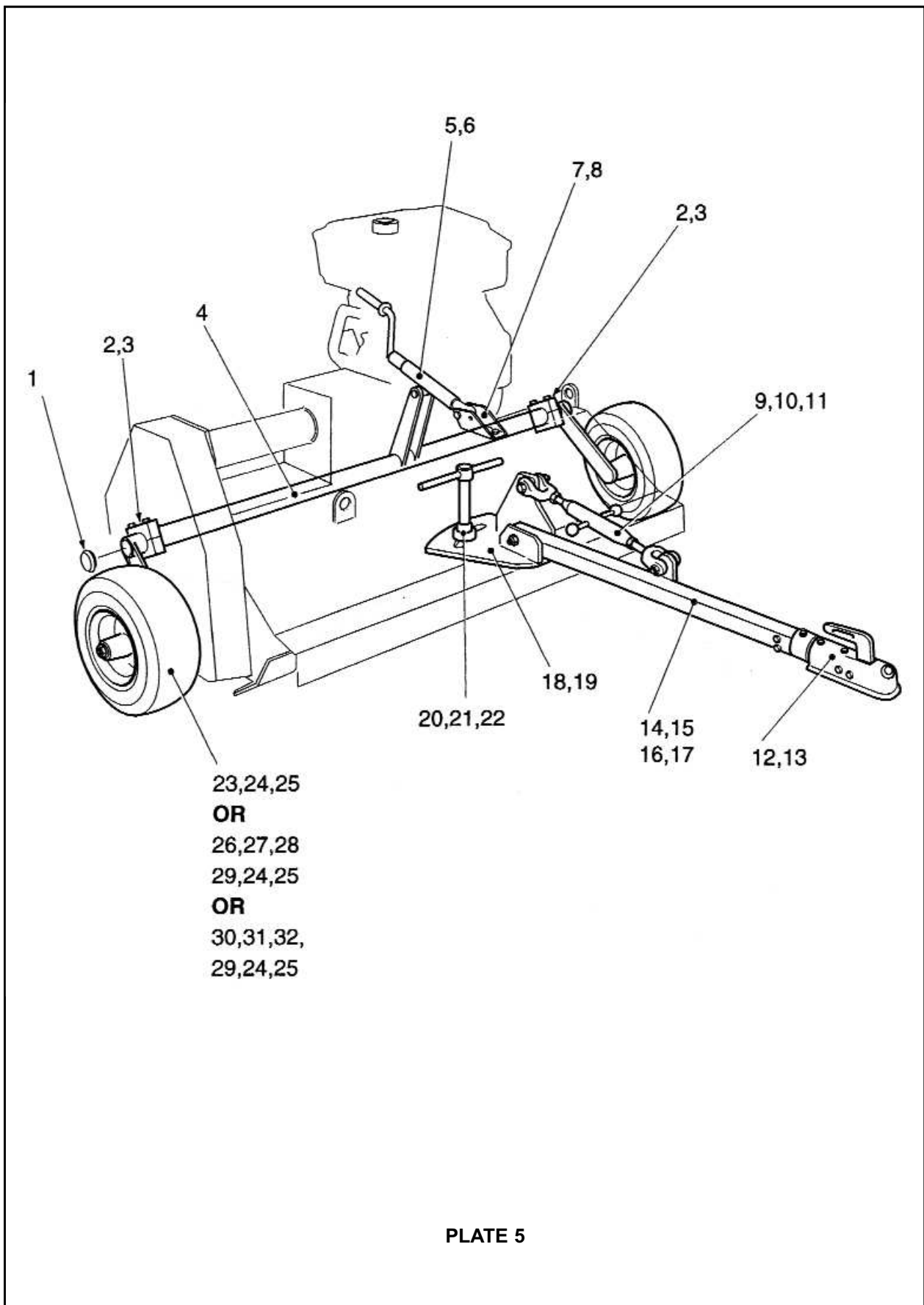

PLATE 4

PARTS LIST - AF & AFC120 FOUR WHEEL ASSEMBLY - PLATE 4

Item No.	Part No.	Description	Qty. per Machine
1	WX-3152	Wheel	4
2	WX-2503	Fastening Set	4
3	WX-8753	Rear Wheel Mounting	1
4	WX-13380	Adjusting Screw Assembly	2
5	WX-0503	Fastening Set	2
6	WX-11251	Adjusting Screw Mount	2
7	WX-0403	Fastening Set	2
8	WX-5228	Pillar	1
9	WX-5228A	Tommy Bar	1
10	WX-3325	Disc Spring	1
11	WX-2356	Tow Hitch	1
12	WX-1503	Fastening Set	1
13	WX-12880	Drawbar	1
14	WX-4503	Fastening Set	1
15	WX-12156	Tow Hitch Swivel Bar	1
16	WX-1403	Fastening Set	1
17	WX-12980	Drawbar Mounting Bracket	1
18	WX-1203	Fastening Set	1
19	WX-5553	Wheel Fork	2
20	WX-1520	Special Washer	2
21	WX-7102	Special Bolt	2
22	WX-8953	Front Wheel Mounting	1
23	WX-11551	Wheel Mounting Support	4
24	WX-2303	Fastening Set	2
25	WX-8853A	Plastic Cap	4
26	WX-2403	Fastening Set	2

PARTS ILLUSTRATION - AFC120 SIDE WHEEL ASSEMBLY



PARTS LIST - AFC120 SIDE WHEEL ASSEMBLY - PLATE 5

Item No.	Part No.	Description	Qty. per Machine
1	WX-8853A	Plastic Cap	2
2	WX-11551	Wheel Mounting Support	2
3	WX-2403	Fastening Set	2
4	WX-8853	Wheel Mounting	1
5	WX-13380	Adjusting Screw Assembly	1
6	WX-0503	Fastening Set	1
7	WX-11251	Adjusting Screw Mount	1
8	WX-0403	Fastening Set	1
9	WX-2029	Drawbar Adjuster	1
10	WX-1129	Adjuster Bar	1
11	WX-1129A	Ball Knob	2
12	WX-2356	Tow Hitch	1
13	WX-1503	Fastening Set	1
14	WX-12880	Drawbar	1
15	WX-4503	Fastening Set	1
16	WX-12156	Tow Hitch Swivel Bar	1
17	WX-1403	Fastening Set	1
18	WX-12980	Drawbar Mounting Bracket	1
19	WX-1203	Fastening Set	1
20	WX-5228	Pillar	1
21	WX-5228A	Tommy Bar	1
22	WX-3325	Disc Spring	1
23	WX-1352	Wheel	2
24	WX-1538	Wheel Bearing Inner	2
25	WX-1638	Wheel Bearing Outer	2
26*	WX-2652	Wheel, HTC	2
27	WX-11651	Wheel Spacer	2
28	WX-9153	Wheel Stud	8
29	WX-9451	Wheel Hub	2
30*	WX-2552	Wheel, Flotation	2
31	WX-11751	Wheel Spacer	2
32	WX-9253	Wheel Stud	8

*This assembly also used on AF120 for HTC and Flotation Wheels.

PARTS ILLUSTRATION - DRIVE SHAFT ASSEMBLY (CENTRE MOUNT)

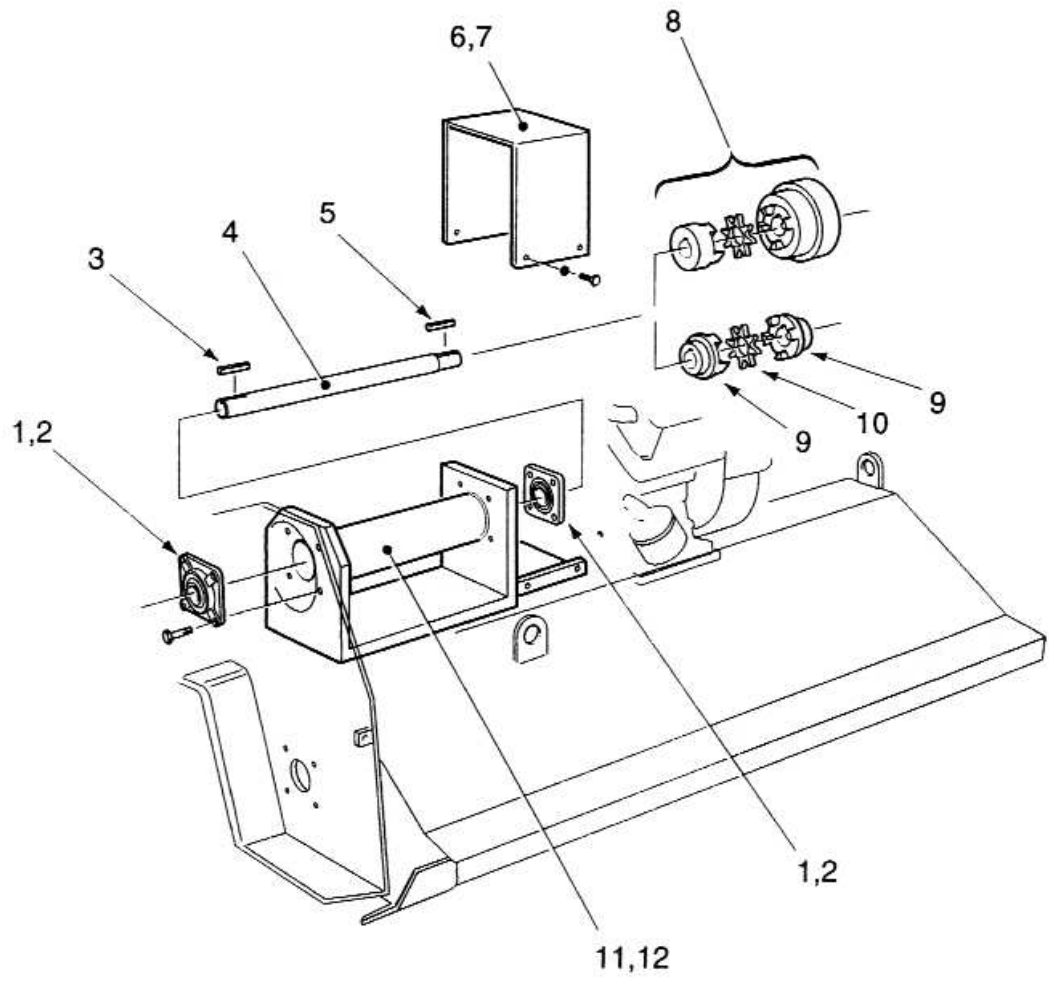

PLATE 6

PARTS LIST - DRIVE SHAFT ASSEMBLY (CENTRE MOUNT) - PLATE 6

Item No.	Part No.	Description	Qty. per Machine
1	WX-0941	Bearing	2
2	WX-1803	Fasteing Set	2
3	WX-0147	Key	1
4	WX-9466	Drive Shaft	1
5	WX-1347	Key	1
6	WX-10477	Transmission Cover	1
7	WX-2703	Fastening Set	1
8	WX-7562	Centrifugal Clutch	1
9	WX-10557	Flexible Coupling Body	2
10	WX-10657	Flexible Coupling Spider	1
11	WX-10357	Drive Shaft Bracket	1
12	WX-2603	Fastening Set	1

PARTS ILLUSTRATION - MANUAL ENGAGEMENT ASSEMBLY

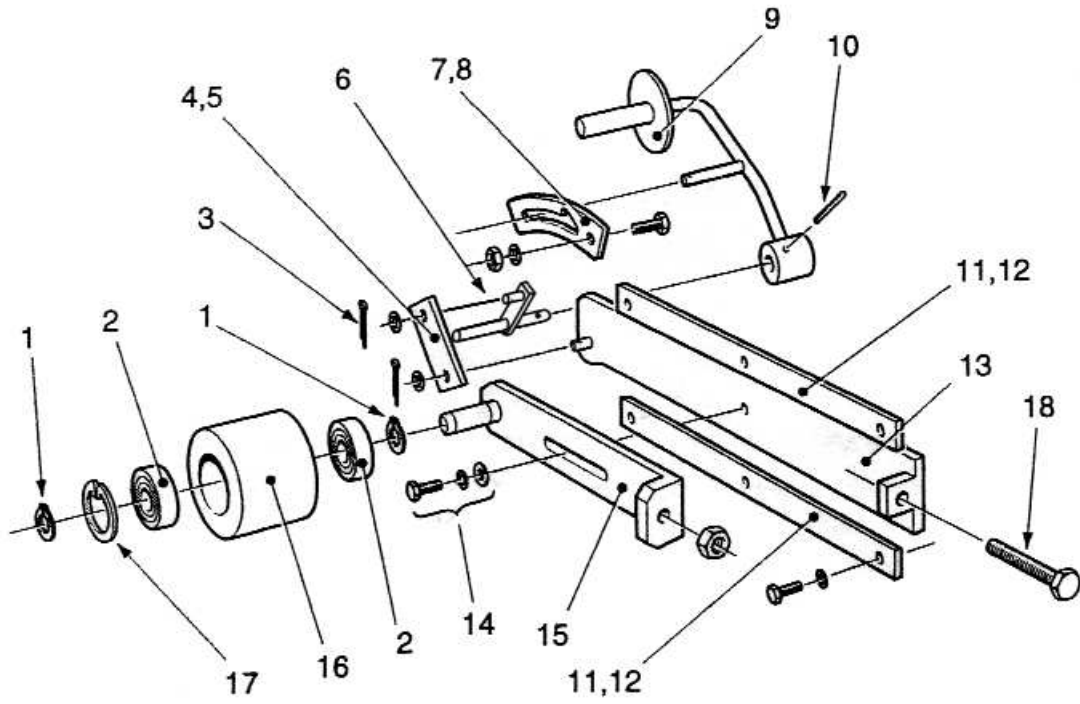
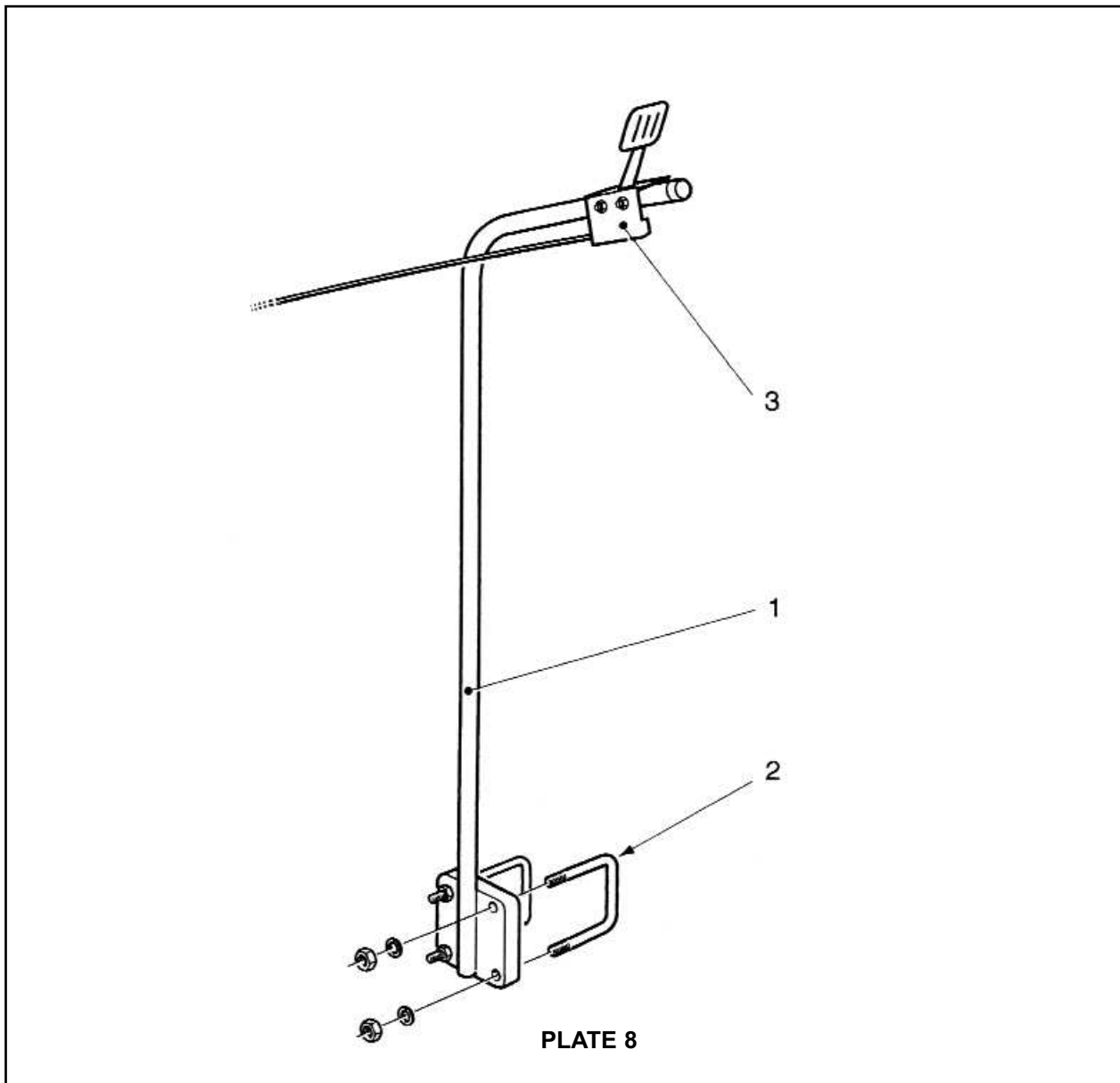

PLATE 7

PARTS LIST - MANUAL ENGAGEMENT ASSEMBLY - PLATE 7

Item No.	Part No.	Description	Qty. per Machine
1	WX-0622	Circlip	2
2	WX-1438	Bearing	2
3	WX-3322	Split Pin	2
4	WX-4758	Link 'B'	1
5	WX-0903	Fastening Set	1
6	WX-4658	Link 'A'	1
7	WX11856	Latch	1
8	WX-1003	Fastening Set	1
9	WX-4558	Clutch Handle	1
10	WX-3222	Coiled Pin	1
11	WX-4358	Slide Strip	2
12	WX-0803	Fastening Set	2
13	WX-9266	Jockey Bracket Mount	1
14	WX-0703	Fastening Set	1
15	WX-9366	Jockey Bracket	1
16	WX-6962	Jockey Wheel	1
17	WX-0722	Circlip	1
18	WX-2725	Adjuster	1

PARTS ILLUSTRATION - CONTROL ARM OPTION



PARTS LIST - CONTROL ARM OPTION - PLATE 8

Item No.	Part No.	Description	Qty. per Machine
1	WX-12480	Control Arm	1
2	WX-7002	'U' Bolt	2
3	WX-6756	Throttle / Cable	1

BELT RETAINER POSITIONING - PLATE 9

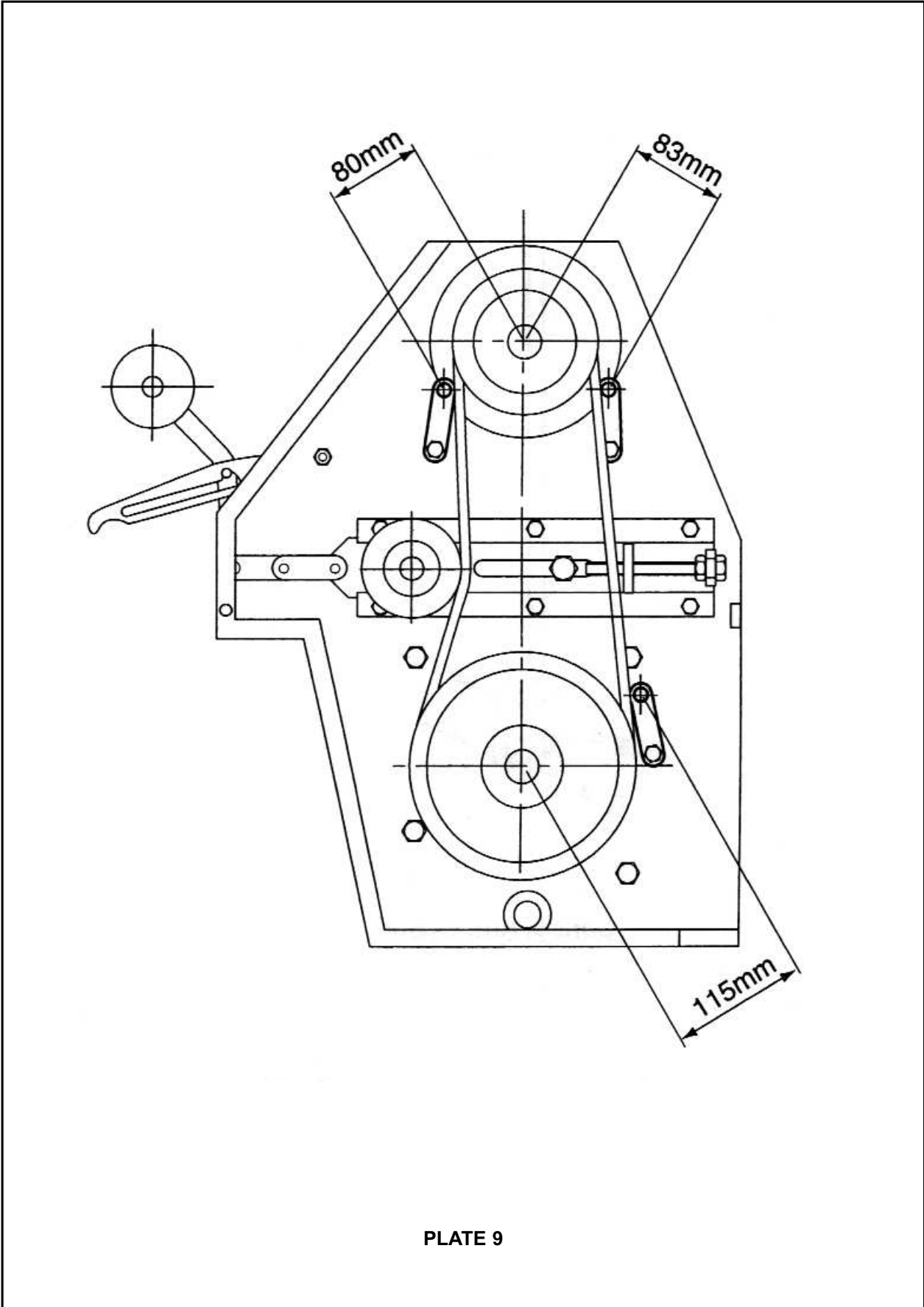
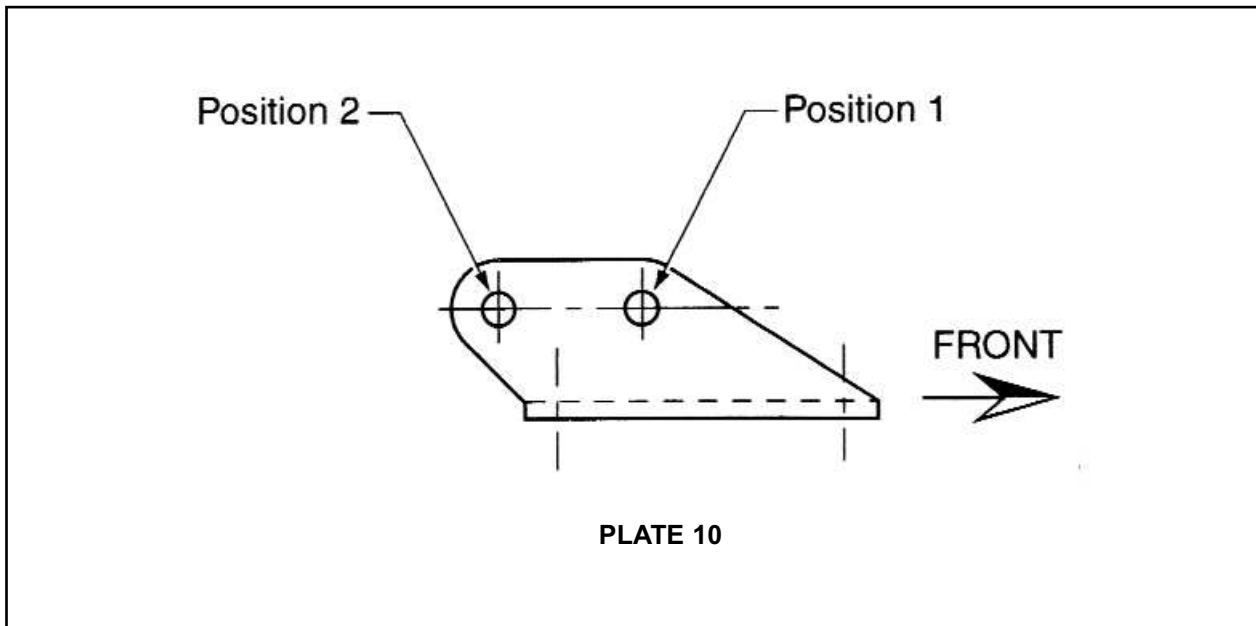

PLATE 9

ADJUSTING SCREW MOUNT - PLATE 10



Pivot Position for Adjusting Screw Assembly

- | | |
|--------------------------------------|------------|
| 1. AF(C) 120, Side Wheel (STD) | Position 1 |
| 2. AF(C) 120, Side Wheel (HTC) | Position 1 |
| 3. AF(C) 120, Side Wheel (FLOTATION) | Position 2 |
| 4. AF(C) 120, Rear Wheel | Position 1 |
| 5. AF(C) 120, Front Wheel | Position 2 |



Certificate of CE Conformity

Machine Model:

AF & AFC 120

Description:

Flail Mower

*I hereby certify that the machine detailed hereon
conforms to:*

**European Directives 2008/42/EC
Supply of Machinery Regulations 2008
As amended 91/368EEC – 93/44EEC – 93/68EEC
HSE AIS 33**

Signed:

A handwritten signature in black ink, appearing to be 'R. J. ...', is written over a dotted line that extends to the right.

Quality Manager

Date:

NOVEMBER 2010

Wessex International

Charlton House, Caxton Place, East Portway Industrial Estate, Andover, Hampshire SP10 3QN
Telephone: 01264 345870 Fax: 01264 345 880

www.wessexintl.com



Wessex International
Charlton House, Caxton Close, East Portway Industrial Estate, Andover Hampshire. SP10 3QN
Telephone: 01264 345870 Fax 01264 345880
e-mail: sales@wessexintl.com

www.wessexintl.com
