

Operation Manual and Parts Book

Wessex 1.5T Trailer

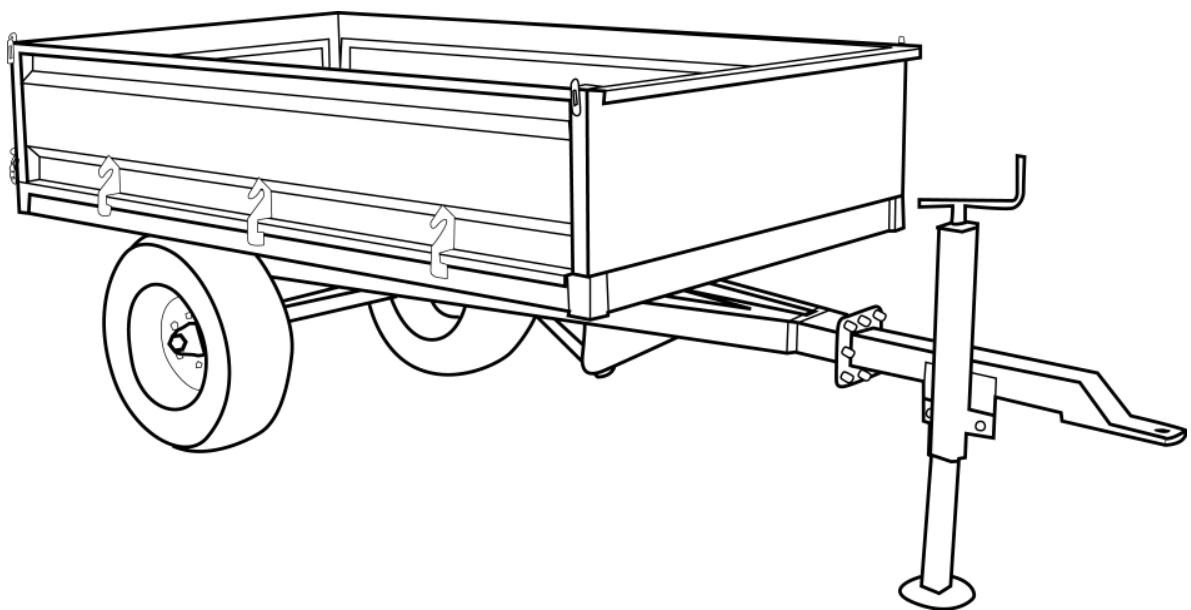

Product Code: L2030

CONTENTS

Welcome to your new Wessex Product2

Safety Decals3

Important Safety Warnings4

Warranty5

Operating Instructions / Using Your Trailer / Maintenance6

Specifications7

Parts Illustration - Mainframe Assembly8

Parts List - Mainframe Assembly9

Parts Illustration / Parts List - Extension Side Set10

CE Certificate11

WELCOME TO YOUR NEW WESSEX PRODUCT

Thank you for purchasing a Wessex product. As a Wessex customer, you now number among the most important people of our business and we will endeavour to give you the best service available through our dealer network.

Please read this Manual carefully and familiarise yourself and other persons that will be using the machine with its contents, to ensure the optimum performance and working life of your machine. It is advisable that a copy of this Manual is kept in the workshop and one copy with the machine. Further copies are available through your dealer.

On delivery, your dealer should go through the workings of the machine with you, explaining the setting up procedures, all of which are contained in this manual for further reference. The Warranty Registration Form must also be completed and returned to us **within 7 days of delivery** in order to validate the Warranty.

**PLEASE READ THE FOLLOWING PAGES CAREFULLY BEFORE USING YOUR MACHINE
AND KEEP THIS MANUAL IN A SAFE PLACE.**



**THIS SAFETY SYMBOL IS TO ALERT OPERATORS OF A HAZARD
THAT MAY RESULT IN INJURY.
ALWAYS FOLLOW INSTRUCTIONS CAREFULLY**

SAFETY DECALS



- GB **ATTENTION** Description of pictograms.
F **ATTENTION** Description des pictogrames.
D **VORSICH** Beschreibung der piktogramme.

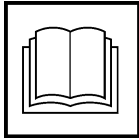

- GB Read Operating manual before use.
F Lisez Manual D'Opération avant l'utilisation.
D Vor der Benutzung, Betriebshandbuch lesen.



- GB Remove Tractors Bottom Link Arms before use.
F Retirer les armes Tracteurs lien du bas avant de l'utiliser.
D Entfernen Traktoren unteren Link Arms vor dem Gebrauch.



- GB Keep clear of unproped body.
F Restez à l'écart du corps unproped.
D Halten Sie Abstand von unproped Körper.



- GB Protective clothing must be worn.
F Vêtements de protection doivent être portés.
D Schutzkleidung getragen werden.

IMPORTANT SAFETY WARNINGS



1. **ALWAYS** stand clear of unproped body.
2. **NEVER** tip body with people nearby, keep everybody (especially children and animals) at a safe distance.
3. **ALWAYS** remove Tractor bottom link arms while towing your Trailer from the pin hitch.
4. **NEVER** load your Trailer in excess of 1.5 Ton gross weight.
5. **NEVER** unhitch a loaded Trailer.
6. **NEVER** tow at above 30 kilometres per hour.
7. **ALWAYS** chock the wheels when parking the Trailer.
8. **NEVER** tip your trailer on sloping ground.

WARRANTY

Your Wessex product or equipment is warranted free from defect in workmanship or manufacture for one year from date of purchase. Any parts which appear to us to be defective, either in material or workmanship shall be replaced or repaired at no cost to the purchaser, subject to the following conditions:

1. The registration card enclosed with this booklet must be returned to us within seven days of purchase.
2. Any failure in the machine should be reported in the first instance immediately to your dealer, who will act on your behalf to resolve the matter to your satisfaction.
3. The defective parts will be returned by your dealer to us, accompanied by a full statement describing the failure and the circumstances and conditions in which the failure occurred.
4. The following are specifically excluded from our terms of warranty:
 - a) Fair wear and tear, especially to belts, brushes, blades and spinners.
 - b) Damage to blades or brushes caused through incorrect positioning of the rotor (see instructions).
 - c) Damage caused by neglect or lack of lubrication.
 - d) Damage caused by misuse or abuse.
 - e) Damage caused whilst the machine is in transit.
 - f) Damage caused to the frame of the machine by running the machine with unbalanced rotors, blades or spinners.
 - g) Damage caused to the machine by use with loose nuts, bolts, screws or any other type of fittings.
5. The warranty is for the benefit of the first user only.
6. Wessex International decisions will be final and binding.

Note:

It is recommended that every machine is inspected after one hour of operation to check that all nuts, bolts, screws or any other types of fixings are tight and any loose fixings or components should be rectified as appropriate.

Further inspections should be carried out at regular intervals thereafter.

OPERATING INSTRUCTIONS

HITCHING UP YOUR WESSEX TRAILER

1. Remove the Tractor Bottom link arms.
2. Reverse the Tractor so that the Trailer drawbar is between the clevis on your Tractor, if need be altering the height of the Trailer drawbar by adjusting the screw jack
3. Secure with either a pickup hitch or a drawbar pin (not supplied) and retain with a linch pin.
4. Connect the hydraulic hose to Tractor tipping pipe.
5. Wind the parking jack into the fully raised position and turn until tight.

USING YOUR TRAILER

1. Take care not to turn the Tractor and Trailer on steep ground, especially when heavily loaded.
2. When loading aggregates and soil with a fore loader, take care to lower the load as much as possible before releasing it into the Trailer.
3. **Never park the Trailer with the body in the tipped position as this will cause corrosion to the Hydraulic ram.**
4. The optional Extension Side Set is supplied purely for use with light loads such as leaves, loose grass clippings and hedge prunings etc.
5. **Never use the extension Side Set to increase the volume of aggregates and heavy material.**
6. The Trailer rear corner posts, side boards and tailgate can be removed when loading bales etc.
7. When using your Trailer on the road always use the rear Lighting Kit and Parking Brake Assembly.

MAINTENANCE

1. Periodically grease wheel bearings.
2. Periodically grease hinge pins.
3. Regularly grease the parking jack.
4. Tyre pressure for standard Trailer and Trailer with parking brake 65 psi max.
5. Tyre pressure for flotation tyres 22 psi max.

SPECIFICATIONS

Maximum Gross Weight	1.5 Ton
Length Excluding Drawbar (m)	2.0
Width (m)	1.2
Side Height (m)	0.38
Loading Height	0.61
Tyre Size	23 x 10.5 x 12

PARTS ILLUSTRATION - 1.5 TON TRAILER MAINFRAME ASSEMBLY - PLATE 1

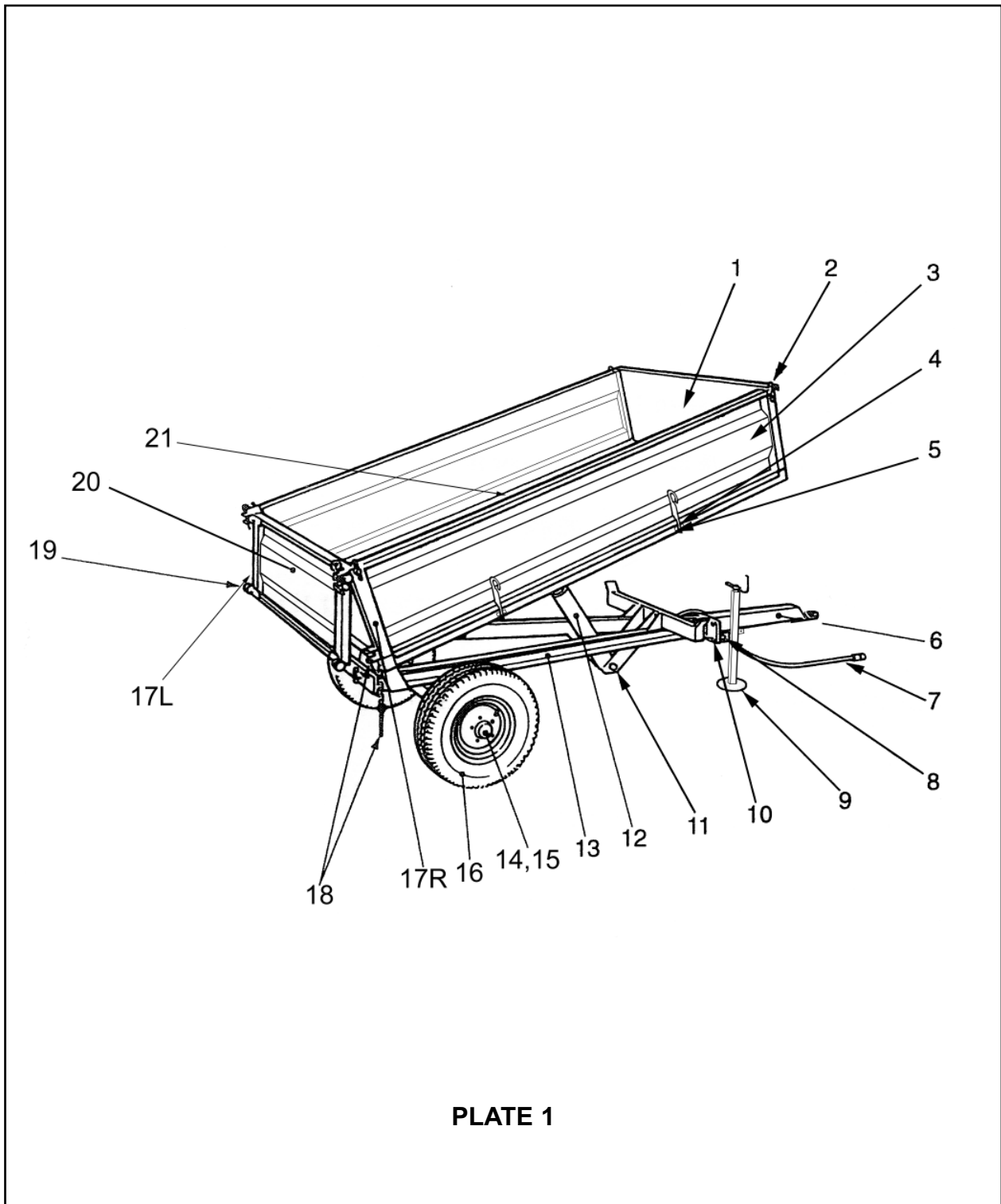
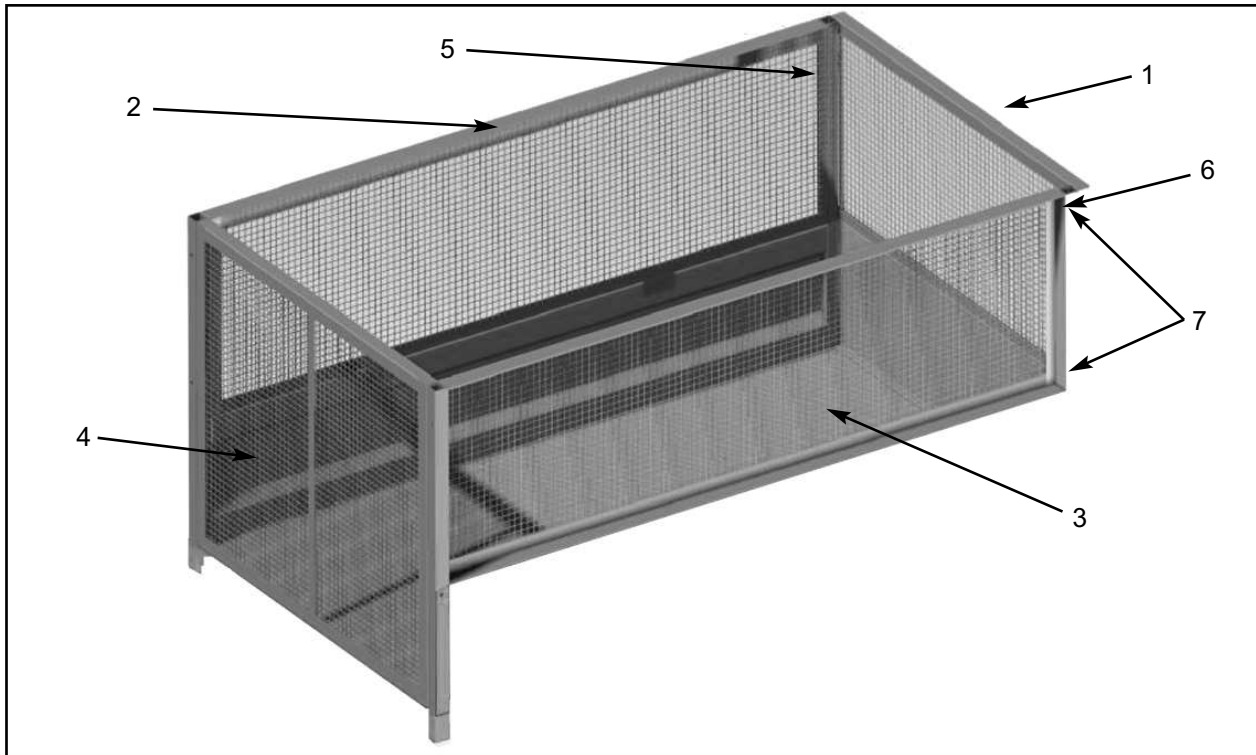

PLATE 1

PARTS LIST - 1.5 TON TRAILER MAINFRAME ASSEMBLY - PLATE 1

Item No.	Part No.	Description	Qty. per Machine
1	WX-14179	Head Board	1
2	WX-0530	Anti-Luce Lug	4
3	WX-13979	Side Board (Left and Right Hand)	2
4	WX-14279/50	Weld on Hinge Hook	4
5	WX-3703	Hinge Hook Fastening Set	1
6	WX-18379	Draw Bar	1
7	WX-0556	Hose Assembly	1
8	WX-1901	Fastening Set Jack Assembly	1
9	WX-0156	Jack Assembly	1
10	WX-19601	Fastening Set Draw Bar	1
11	WX-3202	Fastening Set Ram	1
12	WX-0456	Ram	1
13	WX-14879	Main Chassis	1
14	WX-5653	Hub	2
15	WX-2753	Hub Cap	2
16	WX-2052	Wheel Complete	2
16	WX-2253	Tube	2
16	WX-2153	Tyre	2
N/S	WX-3338	Inner Bearing	2
N/S	WX-3438	Outer Bearing	2
N/S	WX-0845	Hub Oil Seal	2
17L	WX-14279L	Left Hand Corner Post	1
17R	WX-14279R	Right Hand Corner Post	1
18	WX-0730	Forket C/W Cotter and Chain	4
19	WX-0630	Tail Board Lug	4
20	WX-14079	Tail Board	1
21	WX-15179	Main Body	1

PARTS ILLUSTRATION - 1.5 TON EXTENSION SIDE SET - PLATE 2



PARTS LIST - EXTENSION SIDE SET - PLATE 2

Item No.	Part No.	Description	Qty. per Machine
1	WX-16279	Head Board Frame	1
2	WX-16179L	Left Hand Side Frame	1
3	WX-16179R	Right Hand Side Frame	1
4	WX-16379	Tail Gate	1
5	WX-16379L	Left Hand Corner Post	1
6	WX-16379R	Right Hand Corner Post	1
7	WX-0730	Cotter Pin and Chain	4
N/S		Fixing Set Complete	1



Certificate of CE Conformity

Machine Model:

1.5 Ton

Description:

Hydraulic Tipping Trailer

*I hereby certify that the machine detailed hereon
conforms to:*

**European Directives 2008/42/EC
Supply of Machinery Regulations 2008
As amended 91/368EEC – 93/44EEC – 93/68EEC**

Signed:

A handwritten signature in black ink, appearing to be 'R. J. ...', written over a dotted line.

Quality Manager

Date:

August 2011

Wessex International

Charlton House, Caxton Place, East Portway Industrial Estate, Andover, Hampshire SP10 3QN
Telephone: 01264 345870 Fax: 01264 345 880

www.wessexintl.com



Wessex International
Charlton House, Caxton Close, East Portway Industrial Estate, Andover Hampshire. SP10 3QN
Telephone: 01264 345870 Fax 01264 345880
e-mail: sales@wessexintl.com

www.wessexintl.com
