

Spreaders for Snow & Ice Control

FOR MODEL

PRO -1575

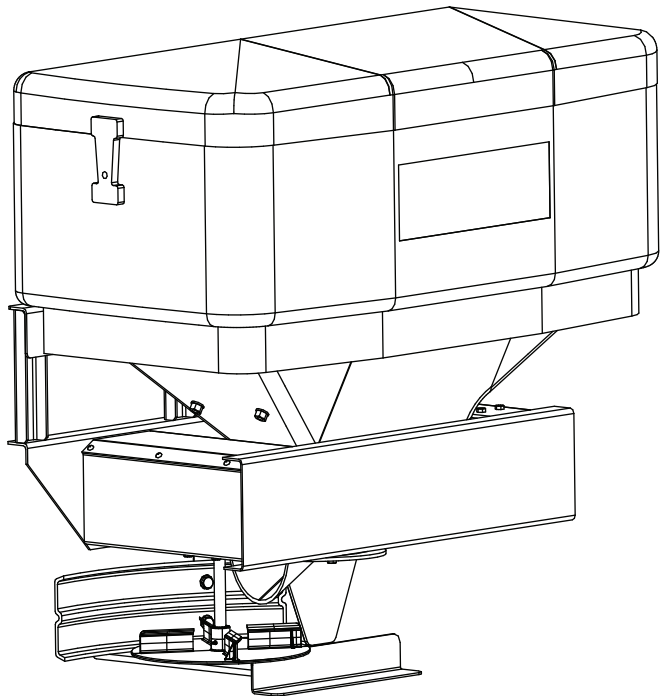

INTRODUCTION.....	3
GENERAL INFORMATION.....	4
REGISTRATION	4
SAFETY PRECAUTIONS	5 - 6
• PREPARATION	
• OPERATIONS	
• SERVICE	
SPREADER PARTS/DIAGRAMS.....	7 - 10
WIRING AND INSTALLATION INSTRUCTIONS	11- 15
OPERATING THE SPREADER	16 - 17
TROUBLESHOOTING	18 - 20
SPREADER MAINTENANCE	21
WARRANTY	22
WARRANTY CARD	23

This manual has been designed for your help. It will assist you and instruct you on the proper set-up, installation and use of this spreader. Refer to the table of contents for an outline of this manual.

We require that you read and understand the contents of this manual completely (especially all safety information) before attempting any procedure contained herein. Extra copies of Owner/Operator Manuals can be purchased at your Snowex Dealer.



THIS SIGN SHOULD ALERT YOU:

The Society of Automotive Engineers has adopted this SAFETY ALERT SYMBOL to pinpoint characteristics that, if NOT carefully followed, can create a safety hazard. When you see this symbol in this manual or on the machine itself, BE ALERT! Your personal safety and the safety of others is involved.

Defined below are the SAFETY ALERT messages and how they will appear in this manual:



DANGER

(RED)

Information that, if not carefully followed, can cause death!



WARNING

(ORANGE)

Information that, if not carefully followed, can cause serious personal injury or death!



CAUTION

(YELLOW)

Information that, if not carefully followed, can cause minor injury or damage to equipment.

General Information



You have purchased a member of the Snowex family, an advanced concept in multi-purpose spreaders.

Our unique design allows many material spreading applications to be addressed. The modular concept allows multiple hitch applications using the same spreader attachments to meet different vehicle types and varied spreading requirements.

Your Spreader may be attached to many types of vehicles ranging from pick-up trucks, sport utilities, tractors, utility vehicles, etc.

The simplicity of construction using high quality steel and deluxe electrostatic finish requires minimal maintenance.

Our poly hopper with custom engineered frame structure, state-of-the-art electronic controller coupled with hi-torque drive assembly will give you ultimate performance and control when spreading.

Snowex reserves the right to make any changes or improve the design of any parts and not be obligated to make changes on units previously sold.

Registration

Record the following information in this manual for quick reference.

Spreader Model Number _____

Spreader Serial Number _____ Controller Serial Number _____

Date of Purchase _____

Dealer Where Purchased _____

When ordering parts, the above information is necessary. This will help to insure that you receive the correct parts.

At the right is a diagram of the ID tag. This tag on the spreader is located on the frame.



Please fill out the warranty card with all the necessary information to validate it. This will also give us a record so that any safety or service information may be communicated to you.



Before attempting any procedure in this book, these safety instructions must be read and understood by all workers who have any part in the preparation or use of this equipment.

For your safety warning and information decals have been placed on this product to remind the operator of safety precautions. If anything happens to mark or destroy the decals, please request new ones from Snowex.



Remember, most accidents are preventable and caused by human error. Exercising of care and precautions must be observed to prevent the possibility of injury to operator or others!



Never operate equipment when under the influence of alcohol, drugs, or medication that might alter your judgment and/or reaction time.



Before working with the spreader, secure all loose fitting clothing and unrestrained hair.



Always wear safety glasses with side shields when working metal against metal. Failure to do this could result in serious injury to the eyes.



Never allow children to operate or climb on equipment.
Never weld or grind on equipment without having a fire extinguisher available.
Always check areas to be spread to be sure no hazardous conditions or substances are in the area.
Always inspect unit for defects: broken, worn or bent parts, weakened areas on spreader or mount.



Always shut off vehicle and power source before attempting to attach or detach or service spreader unit. Be sure vehicle/power source is properly braked or chocked.



Always make sure personnel are clear of areas of danger when using equipment.



Always keep hands, feet, and clothing away from power-driven parts.



Remember, it is the owner's responsibility to communicate information on safe usage and proper maintenance of all equipment.



WARNING

Never exceed 45 m.p.h. when loaded spreader is attached to vehicle. Braking distances may be reduced and handling characteristics may be impaired at speeds above 45 m.p.h.



CAUTION

Never use wet materials, or materials with foreign debris in the SP-1575. This unit is designed to handle dry, clean, free-flowing material. Note: Can not spread water softener salt.



CAUTION

Never leave material in hopper for long periods of time. Be aware that all ice melters are hygroscopic and will attract atmospheric moisture and harden up.



WARNING

Always inspect pins, and latches whenever attaching or detaching spreader, and before traveling.



WARNING

Inspect the unit periodically for defects. Parts that are broken, missing, or worn out must be replaced immediately. The unit, or any part of it should not be altered without prior written permission from the manufacturer.

PRO 1575
Exploded Assembly

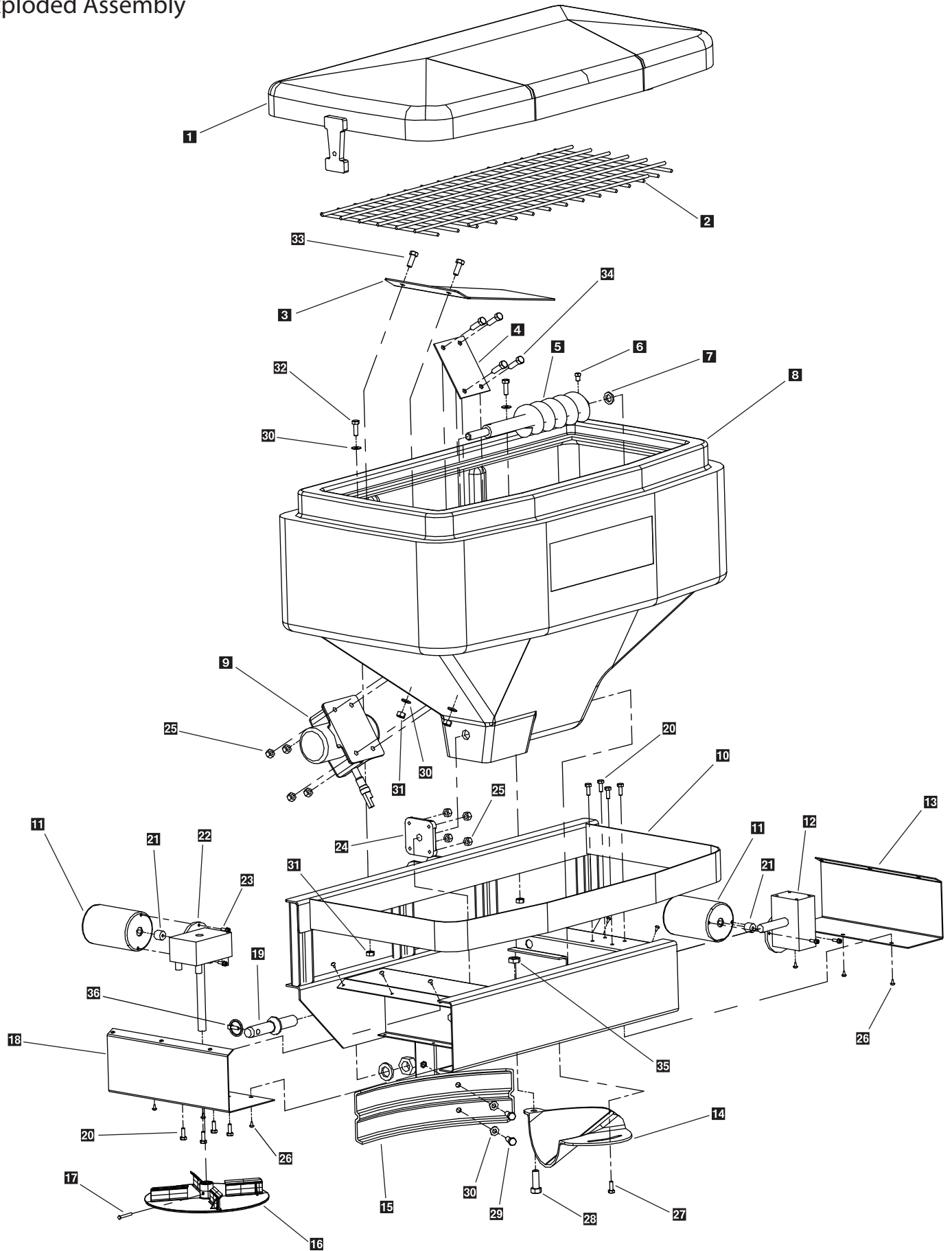

PRO 1575

MAIN ASSEMBLY PARTS BREAKDOWN

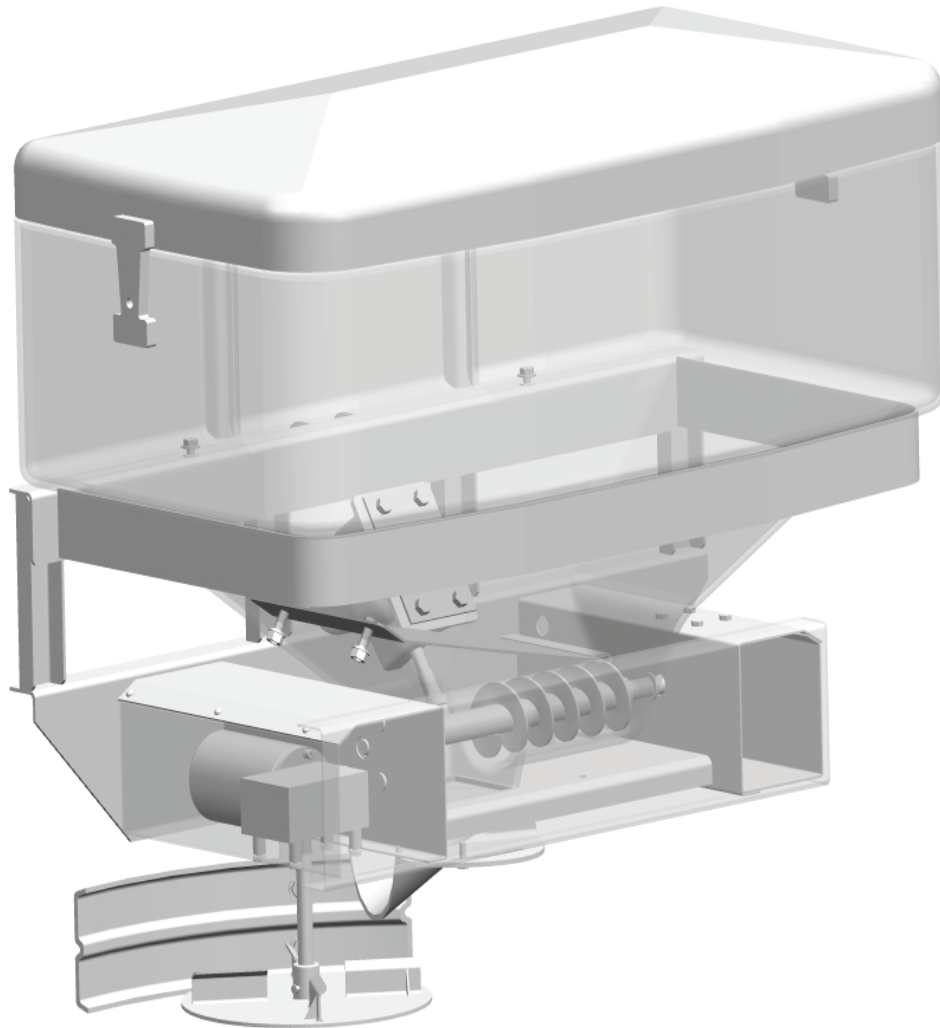

Key	Part No.	Description	Qty.	Key	Part No.	Description	Qty.	Key	Part No.	Description	Qty.
1	D6240	1575 Lid Assembly	1	16	D6750	4 Flite Plastic Spinner	1	31	D5706	5/16-18 Serr. Hex Nut	4
2	D6257	1575 Top Screen	1	17	D6746	Ball Detent Pin	1	32	D6166	5/16-18 x 1 Hex Bolt	2
3	D5114	1 Pc. Material Baffle	1	18	D5106	Spinner Motor Cover	1	33	D6137	5/16-18 x 1-1/4 PH Screw	2
4	D5119	Vibrator Backing Plate	1	19	D5121	7/8 x 5/8 Clevis Pin	2	34	D4122	3/8-16 x 1-1/2 HH	4
5	D5105	10" Auger Assembly	1	20	D6131	1/4-20 Serr. Hex Bolt	8	35	D4120	1/2-13 Lock Nut (see pg 9)	
6	D6140	5/16-18 x 1/2 Set Screw	1	21	D6232	Motor Trans Coupler	2	36	D4133	5/16 Lynch Pin	1
7	D5115	5/8 USS Nylon Washer	1	22	D6107	Spinner Transmission	1				
8	D5100	1575 Yellow Hopper	1	23	D6172	10/32 x 5/8 Serr Flg Bolt	4				
9	D6174	12 Vdc Vibrator	1	24	D6512	Auger Bearing W/Cap	1				
10	D5102	1575 Main Frame	1	25	D6584	3/8 Serrated Flg Nut	8				
11	D6320	Auger & Spinner Motor	2	26	D6130	3/16 Blk Alum Rivet	12				
12	D6566	Auger Transmission	1	27	D6874	1/4 x 1-1/2 Self Driller	1				
13	D5107	Auger Motor Cover	1	28	D4123	1/2-13 x 1-1/2 HH	1				
14	D5118	Plastic Material Chute	1	29	D4121	3/8-16 x 1 Hex Head	2				
15	D6327	Plastic Deflector	1	30	D4125	3/8 Flat Washer	6				

PRO 1575 Mount Assembly

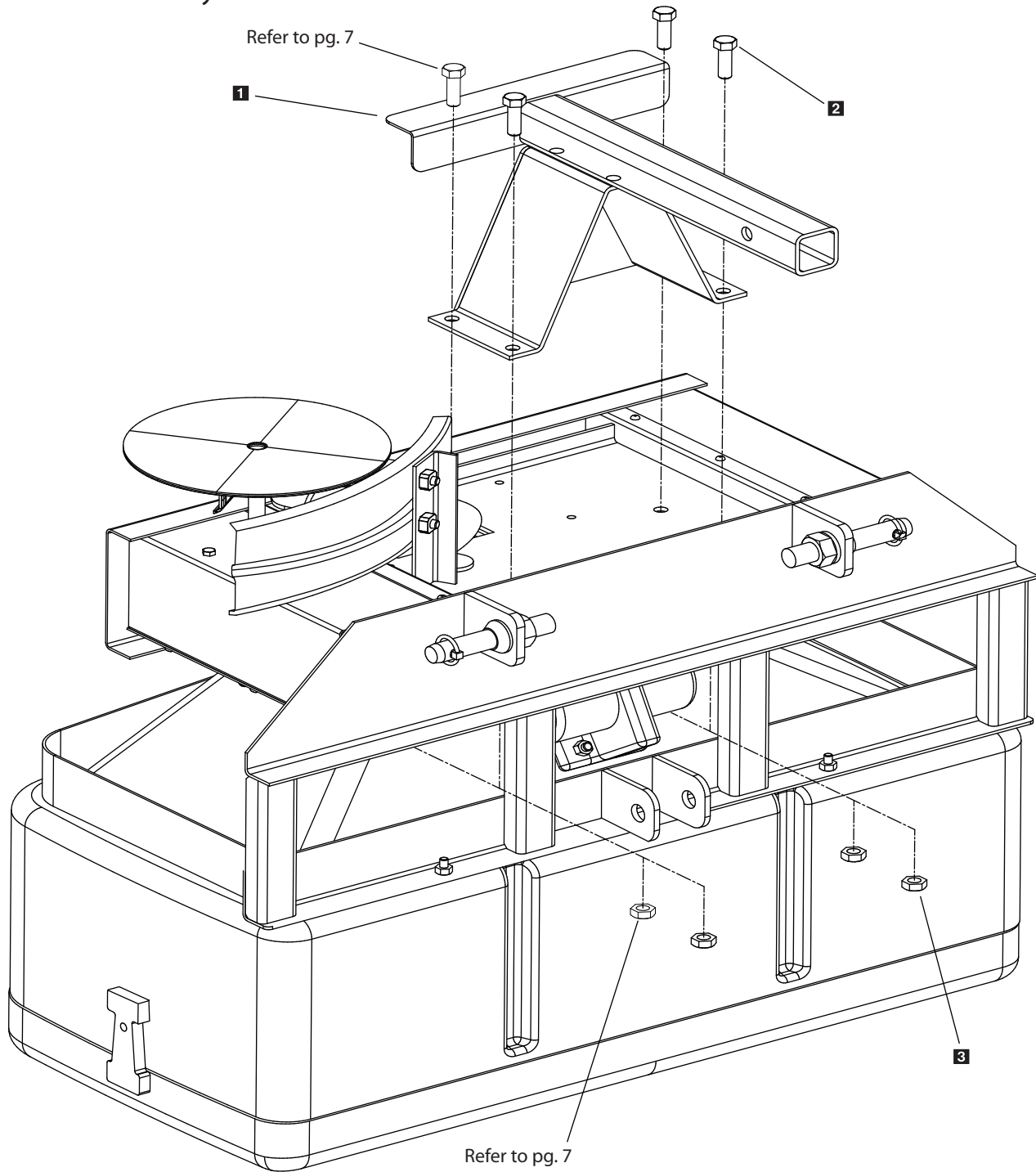

Key	Part No.	Description	Qty.
1	D5104	2" Receiver Mount	1
2	D4116	1/2-13 x 1 Hex Head Bolt	3
3	D4120	1/2-13 Lock Nut	3

PRO 1575
Assembly Views

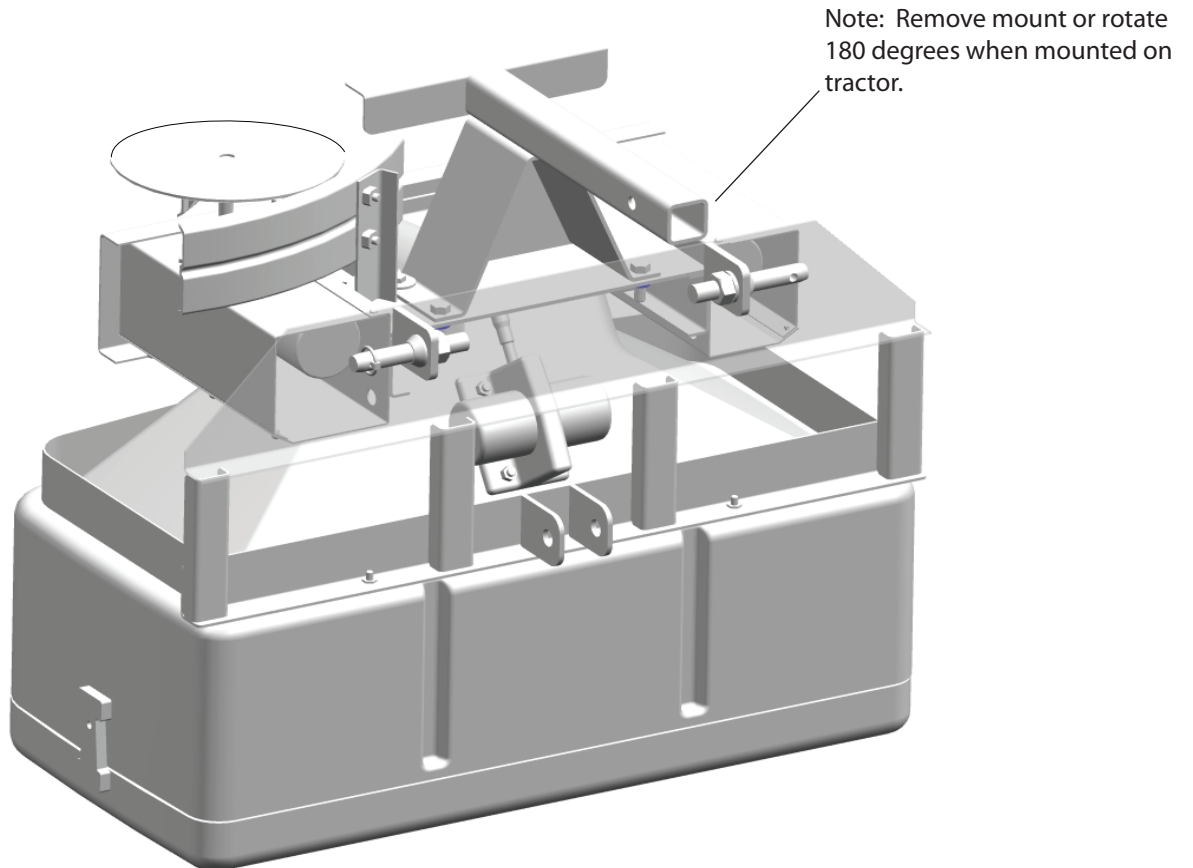
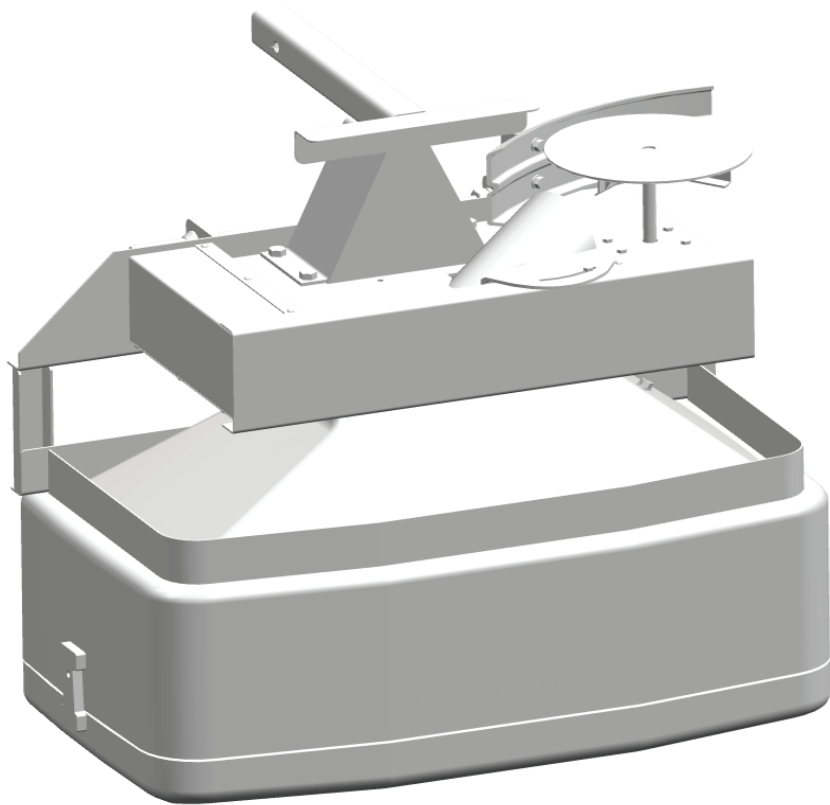

PRO 1575

Assembly Instructions

- Step 1. Reverse 2" receiver mount when you remove the unit from the shipping carton. The mount was installed in a reversed position in order for the unit to fit in the carton. Refer to page 10 for illustration information
- Step 2. You can leave the mount in the shipped position if you intend on using spreader on a tractor 3 point mount. Refer to page 10 for illustration information.

PRO 1575

Wiring Instructions

Step 1: Take harness assembly and route from the rear of the vehicle to the front. Route harness along frame and attach to frame holes and frame supports. It is not recommended to attach to fuel or brake lines for obvious reasons. Do not route close to exhaust system or engine, even though Trynex uses high temperature wiring, it still could melt under extreme heat and short the spreader electrical system, as well as the vehicle electrical system.

Step 2: Mount rear plug on bumper using supplied bolts, locate towards the center of the bumper to reduce the amount of debris the tires will throw to the rear. Important: Apply a small amount of dielectric grease to the plug.

Step 3: Secure harness from the rear to the front using heavy duty ty-wraps or frame clips along the frame and lighter duty ty-wraps everywhere else.

Step 4: Layout harness portion that connects to the battery along the fire wall and fender well. Do not connect power leads to battery yet. Drill a 3/4" hole in the fire wall, or use existing access hole, for the control portion of the harness and route connector and harness through hole. Be sure to check the area on the other side of the fire wall to make sure you are not going to drill into the vehicle harness or a control module. Generally you can drill on either side of the steering column for a good location.

Step 4A: The power harness from control box to battery will need to be routed from the inside of the cab to the battery – this results from the large high amperage connector. Route leads with lugs to battery — do not connect power at this time.

Step 5: Connect harness to the back of the controller and mount to a suitable location. NOTE: You may want to contact customer before mounting controller, some prefer not to have holes drilled into the dashboard. Ty-wrap loose controller harness and move to the engine compartment.

Step 6: Connect power leads to the battery: Red + Positive, Black – Negative. Always connect to the primary battery if using a dual battery system, secure loose loom to any other large or medium vehicle harness with medium duty ty-wraps. This will secure wiring harness.

Step 7: Push the ON/OFF button on the controller to check for power, when that has been confirmed turn power OFF. The electrical portion of the installation is complete.

NOTE: If adding an inline fuse, use a 60 amp slow blow (time delay) or a 60 amp relay.

PRO 1575

Electrical System

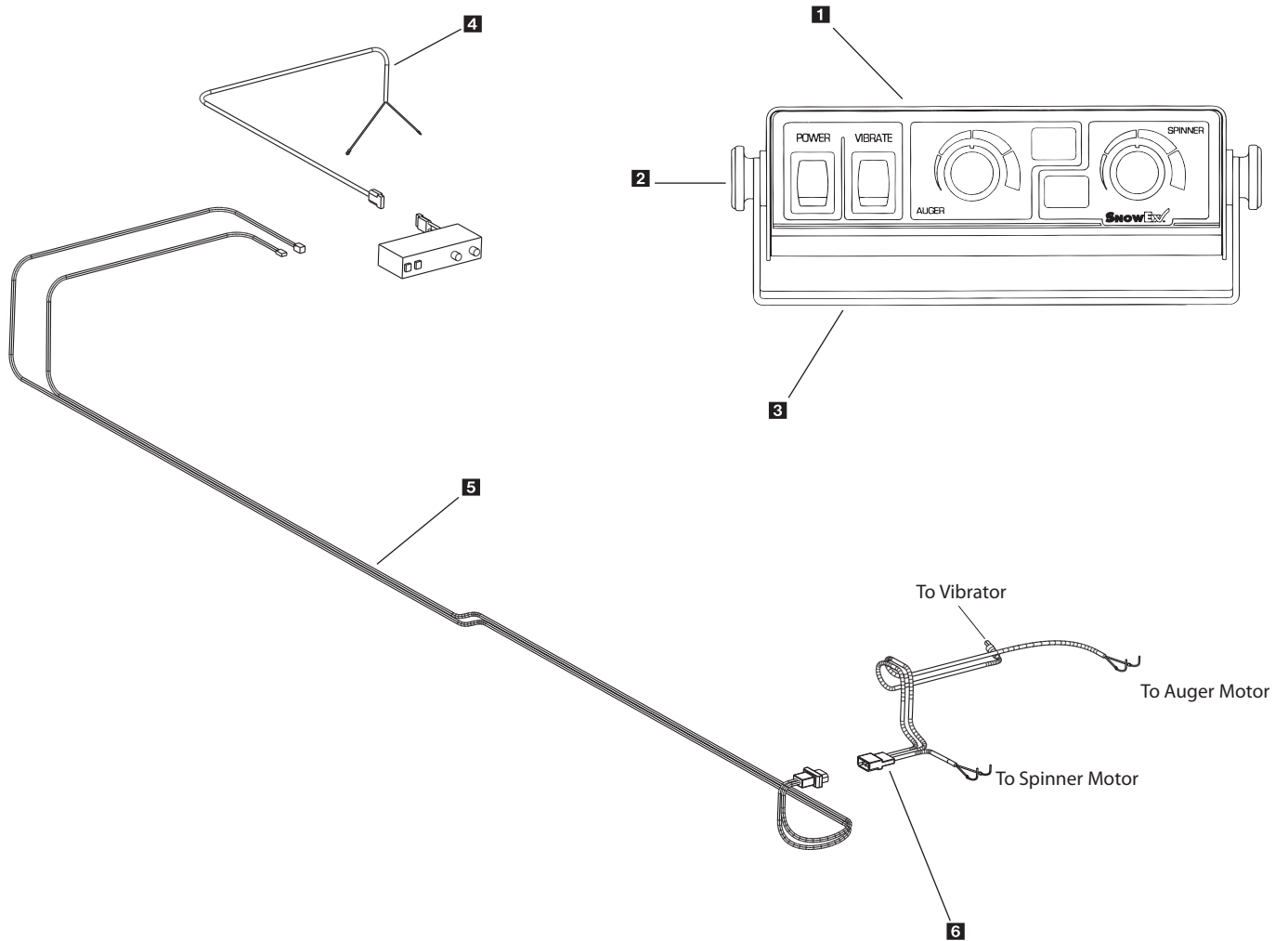

Special Notes:

1. All external connections must have dielectric grease.
2. Read lead labels before attaching to power source or ground.
3. No other devices may be spliced into wiring harness.
4. Any repairs to wiring harness must be done with heat shrink butt connectors.
5. If inline fuse is installed, use a 60 amp maxi fuse or circuit breaker.

Key	Part No.	Description	Qty.
1	D 6527	1575 Controller	1
2	D 6124	Bracket Knob	2
3	D 6329	1575 Controller Bracket	1
4	D 6341	Control Power Cable	1
5	D 6322	1575 Wiring Harness - 25'	1
6	D 6321	Power Cord - 48"	1
	D 6118	Dust Cover (not shown)	1
	D 6344	Dielectric Grease - 1 1/2 oz. (not shown)	1

D6322 Vehicle Harness Circuit Diagram

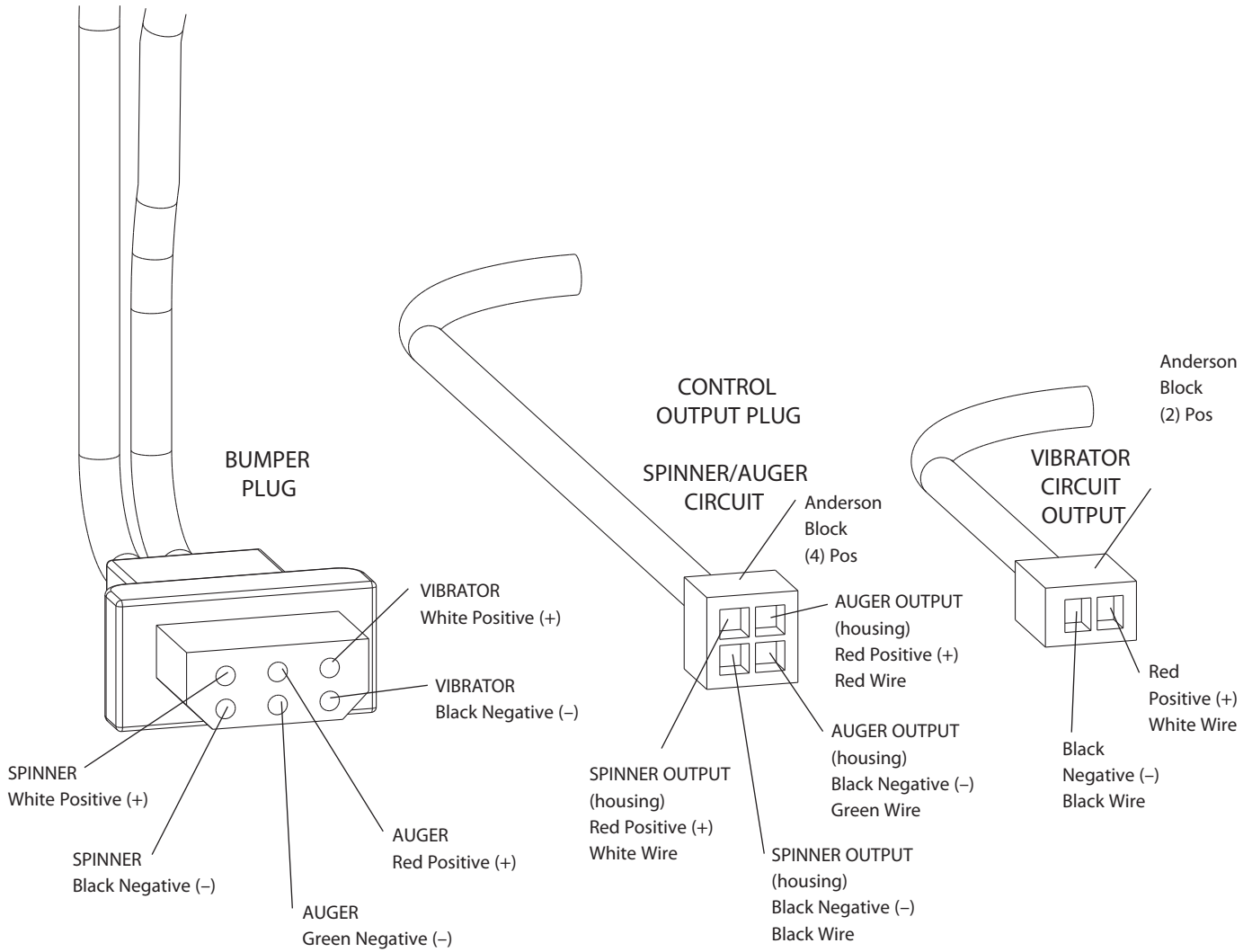

* NOTE: Reference Bumper Plug for Color Code

PRO 1575

D6321 Spreader Power Harness Circuit Diagram

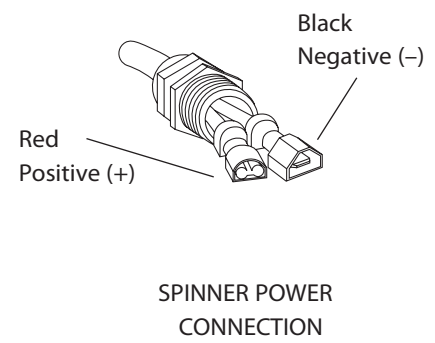
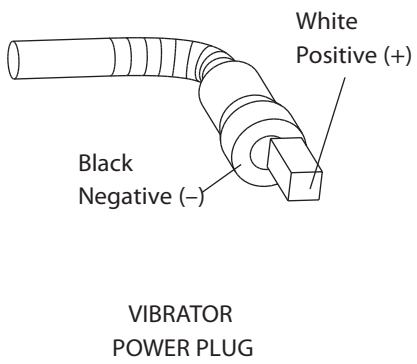
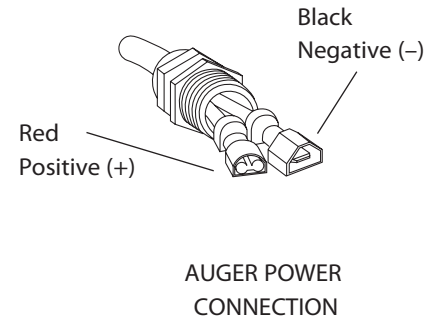
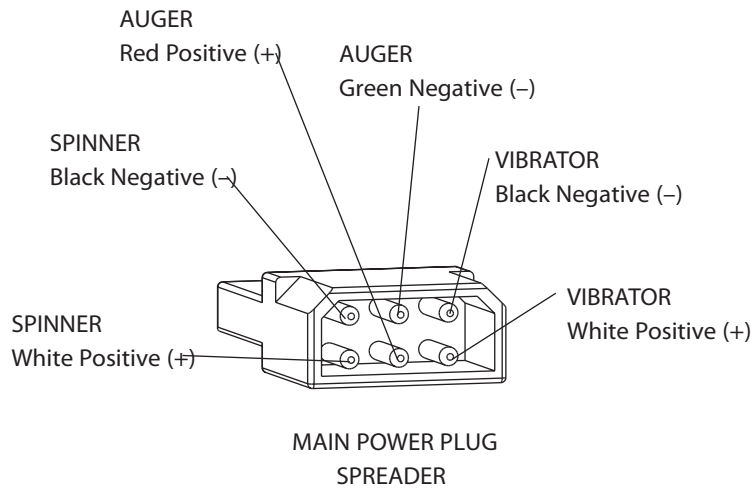

PRO 1575
D6527 Control

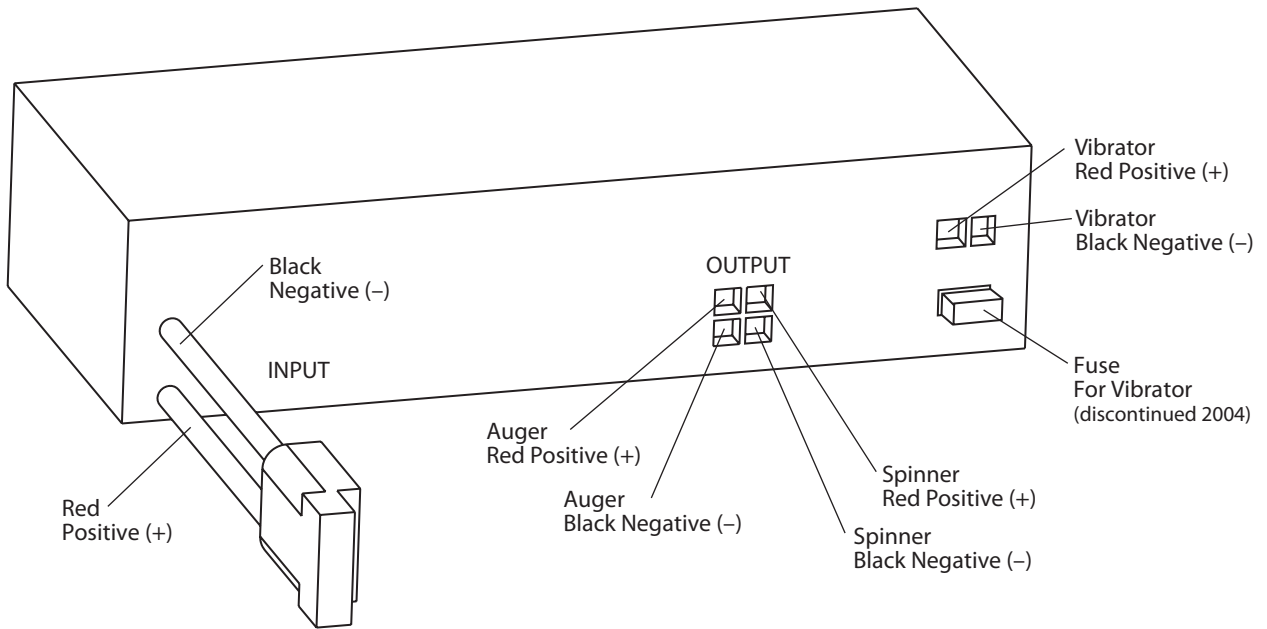

D6341 Control Power Cable

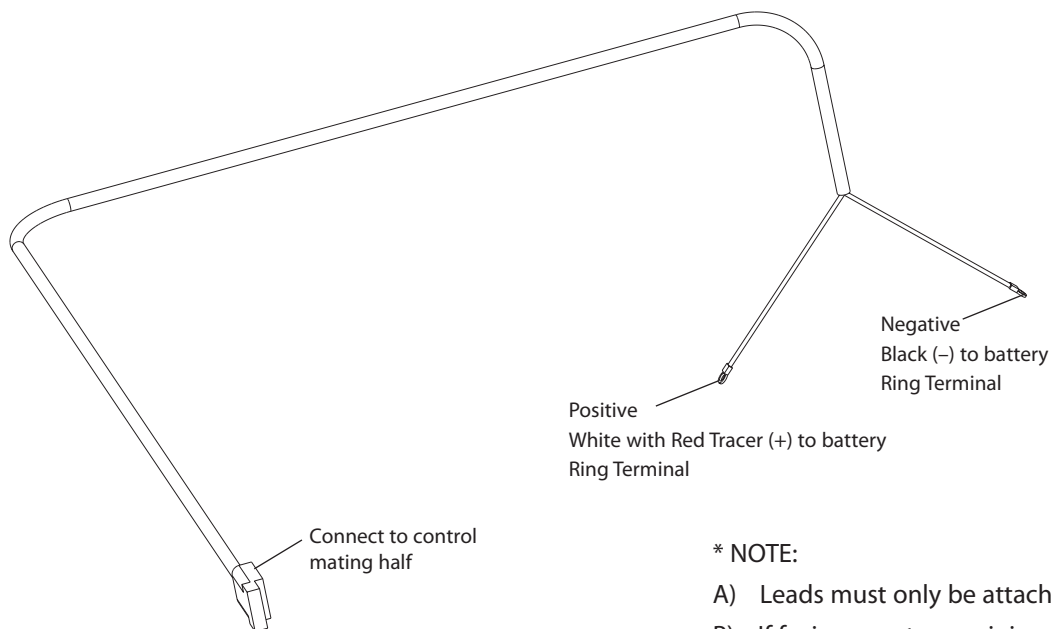

* NOTE:

- A) Leads must only be attached to battery.
- B) If fusing, must use minimum 60 Amp Maxi type fuse.

PREPARATION

CAUTION – Sweep area clear of foreign objects or obstacles that could cause personal injury. Keep other persons, children, or animals out of the area to be spread.

SPREADER LOADING

WARNING –Do not overload vehicle. Use chart below to calculate weight of material. Weights of material are an average for dry materials

<u>Material</u>	<u>Weight Per Cubic Ft.</u>
Rock Salt	35-40 lbs.
Sand/Salt Mix	95-120 lbs.

- Be sure to comply with manufacturer’s maximum gross vehicle weight ratings.
- Warning– Never leave materials in hopper for long periods of time as salt is hygroscopic and will attract atmospheric moisture and harden up. When spreading sand mix, a 1:1 ratio for Sand/Salt mix is recommended to prevent the material from freezing.

SPREADING TIPS

- Never exceed 10 m.p.h. when spreading.
- For a wider pass, increase spinner speed.
- For a heavier pass, drive slower, or increase auger speed.
- Never operate spreader near pedestrians.
- Spread ice melters with the storm to prevent unmanageable levels of ice.
- Calculate spread pattern when near vegetation.

PRO 1575

- The Dual Variable Speed Control has dual finger-tip dials for maximum performance, digital system status with warning protection and built-in Vibrator Switch.
- To start, press power switch on controller and spreader will accelerate to speed set on spinner and auger dials.
- To stop, press power switch on controller to off position.
- Speed of auger and spinner may be adjusted separately to get desired flow and spread distance from spreader.
- The Vibrator Switch is needed for dense material or to increase the flow to the auger. This eliminates bridging of material in hopper.
- A Material Baffle has been installed in your spreader to stop fine material from free-flowing. If using dense or damp material, or if more flow is desired, remove Material Baffle. However, it is recommended that the Material Baffle remain in place if using bulk salt.

AUTO-REVERSE "AR" FUNCTION

- If your controller displays "OL" this could indicate a jammed auger.
- To engage the Auto-Reverse "AR" function:

Step 1: Shut the Main Power Switch OFF for 3 seconds.

Step 2: Turn the Main Power Switch ON. When the machine starts back up the "AR" sequence will automatically start and the auger will reverse for several rotations to clear the jam.

- After a pause of several moments, the auger will automatically return to correct rotation.
- If the jam is still not cleared, the controller will again display "OL".
- You may repeat Steps 1 & 2 for a second and third time.
- If after the third try the controller displays "OL" — you must extract the material that is causing the problem.
- Follow all warning directions when clearing jams.

WARNING PROTECTION

- If audible beeping occurs, read display to identify problem. If display reads "OL" (overload) or "OH" (overheat), shut controller down and carefully clear jammed auger. If display reads "E1" this means there is a dead short in system. Do not use until problem is corrected. If display reads "E0", this means that the motor is not getting any power. Check all connections. If display reads "LB", the vehicle battery is extremely low and could damage system or a poor connection exists.
- If there are any problems while operating the spreader, refer to Troubleshooting Guide.

Whenever service is necessary, your local Snowex Dealer knows your Spreader best. Take your Spreader to your local dealer for any maintenance or service needs on your unit. If this is not possible, the Troubleshooting Guide below may assist you in locating the problem.

Warning: First read all warning instructions and safety messages before servicing your spreader.

Preliminary Checks

- Be sure all electrical connections are tight and clean.
- Be sure nothing is jammed in the hopper.

PROBLEM	POSSIBLE CAUSE	SOLUTION
Motor doesn't run.	Loose electrical connections.	Check all connections.
	Blown Fuse.	Replace fuse.
Controller shut down.	Motor Seized.	Replace motor.
	Jammed auger.	Carefully clear jammed material.
	Poor electrical connections.	Clean or replace connectors. Use dielectric grease.
	Electrical short.	Check electrical connections. Check for bare wires.
Material not flowing from hopper.	Controller failure.	Replace controller.
	Empty hopper.	Fill hopper.
	Wet material.	Replace with dry material.
	Frozen or coarse material.	Replace material.
	Spinner not turning.	Check drive assembly.
Auger loose on shaft.	Tighten locking bolt on the side of the auger. There is a flat machined on the driver shaft. Align the auger with this flat and tighten the bolt.	

PRO 1575

Troubleshooting Spreader

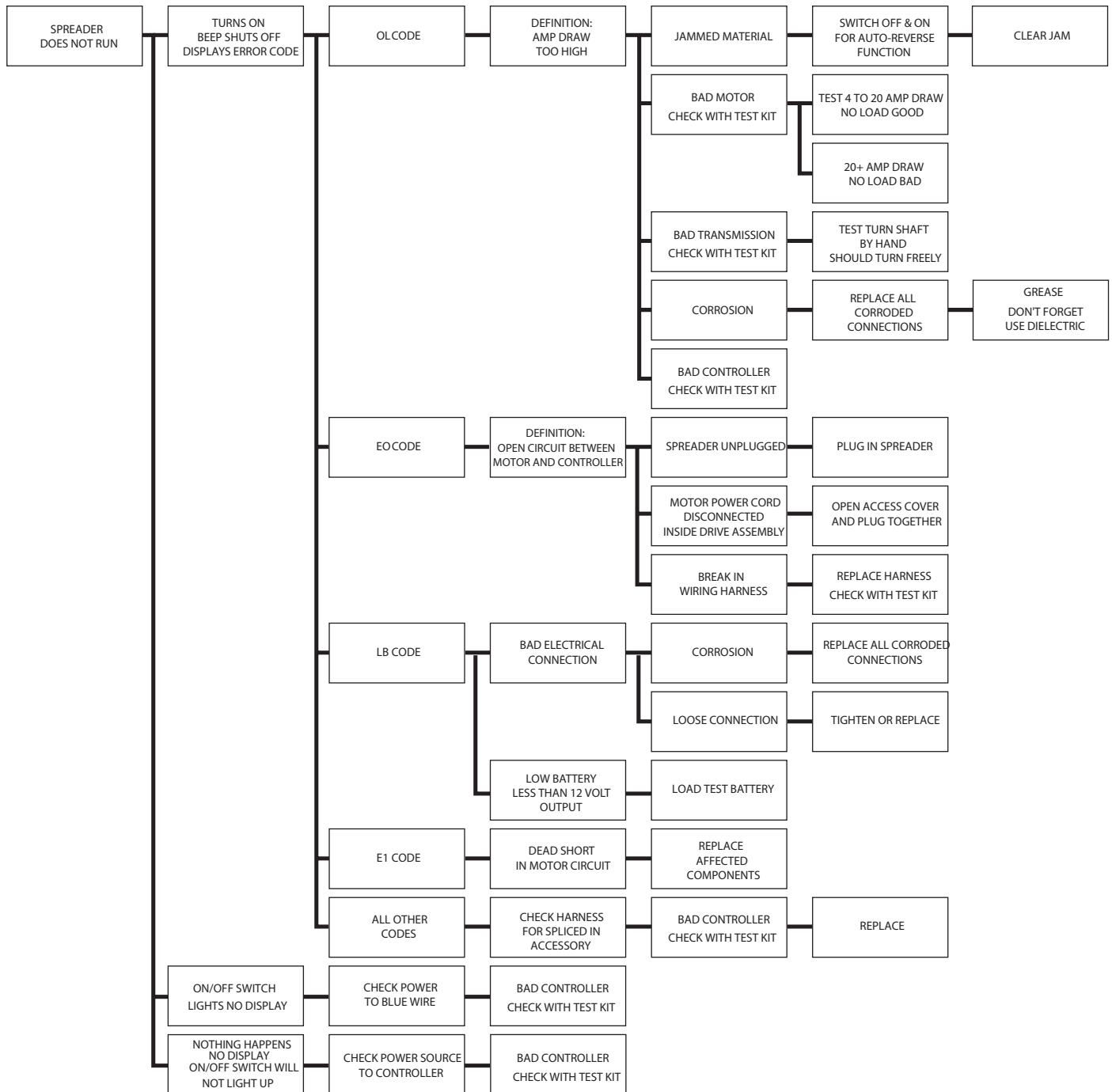

SNOWEX DIAGNOSTIC TEST KIT (STK-020) IS AVAILABLE TO ACCURATELY DIAGNOSE ANY ISSUES WITH SNOWEX SPREADERS. CALL YOUR DEALER FOR DETAILS.

Troubleshooting Material Flow

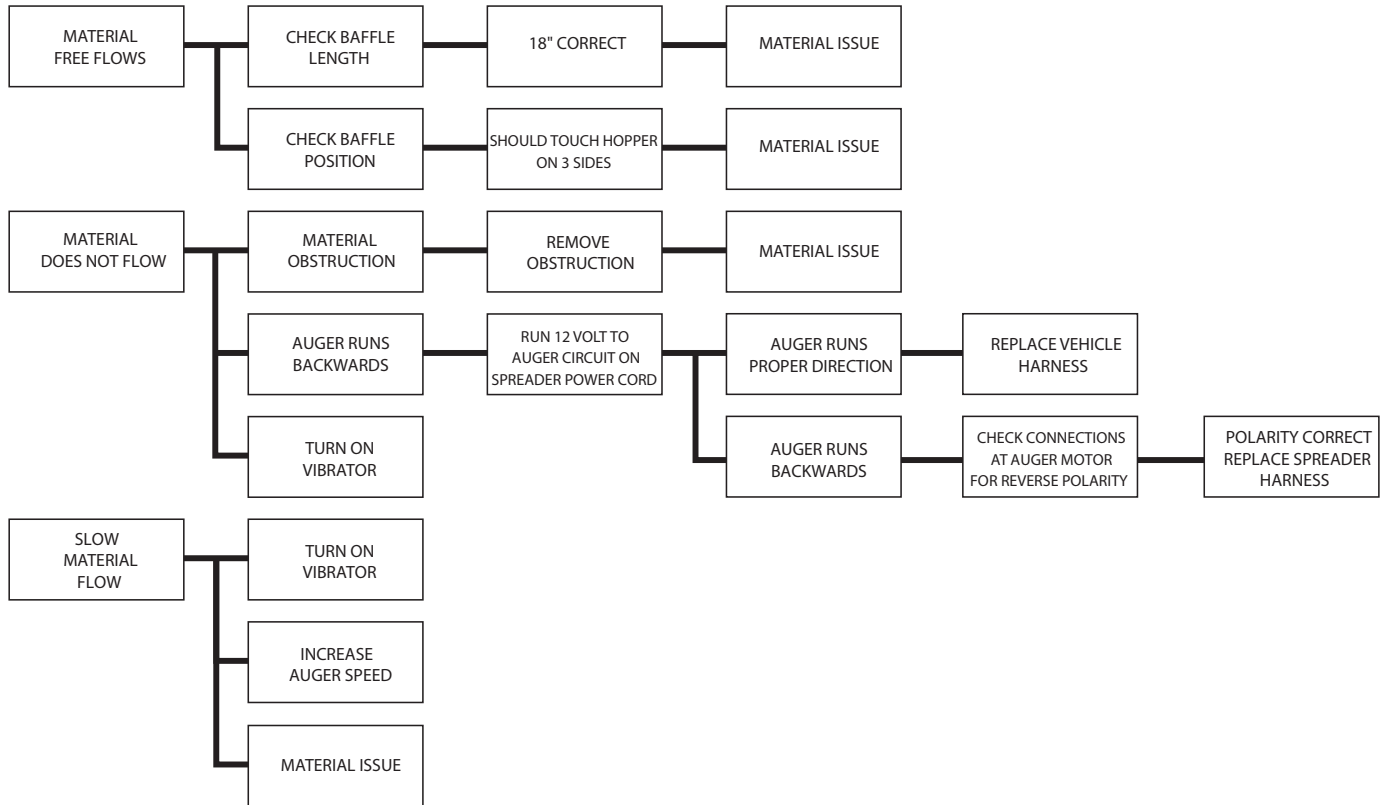

- **WARNING** – When servicing is necessary, perform it in a protected area. Do not use power tools in rain or snow because of danger of electrical shock or injury. Keep area well lighted. Use proper tools. Keep the area of service clean to help avoid accidents.
- **WARNING** – Disconnect electricity to spreader before servicing.
- **CAUTION** – The controller is a solid state electronic unit and is not serviceable. Any attempt to service will void warranty.
- **CAUTION** – There are no serviceable parts in the motor/transmission assembly. Any attempt to service will void warranty.
- **CAUTION** – When replacing parts, use only original manufacturer's parts. Failure to do so will void warranty.
- Use dielectric grease on all electrical connections to prevent corrosion at the beginning and end of the season and each time power plugs are disconnected.
- Wash unit after each use to prevent material build-up and corrosion.
- **CAUTION** – When pressure washing motor enclosure area, stay at least 36" away from motor enclosures.
- Paint or oil all bare metal surfaces at the end of the season.
- If motor cover is removed for any reason, use silicone sealant to ensure weather proofing of enclosure.
- After first use, tighten all nuts and bolts on spreader and mount.

Limited Warranty

Snowex products are warranted for a period of 24 months from the date of purchase against defects in material or workmanship under normal use and service, subject to limitations detailed below. **Warranty period of 24 months** begins on the date of purchase by the original retail user.

The WARRANTY REGISTRATION CARD must be returned to the manufacturer for this warranty to become effective. This warranty applies to the original retail purchaser only. This warranty does not cover damages caused by improper installation, misuse, lack of proper maintenance, alterations or repairs made by anyone other than authorized Snowex dealers or Snowex personnel. Due to the corrosive properties of the materials dispensed by spreaders, Snowex does not warrant against damage caused by corrosion. Warranty claims by the user must be made to the dealer from where the product was purchased, unless otherwise authorized by Snowex. Snowex reserves the right to determine if any part is defective and to repair or replace such parts as it elects. This warranty does not cover shipping costs of defective parts to or from the dealer.

LIMITATION OF LIABILITY

Neither Snowex, nor any company affiliated with it, makes any warranties, representations or promises as to the performance or quality other than what is herein contained. The liability of Snowex to the purchaser for damages arising out of the manufacture, sale, delivery, use or resale of this spreader shall be limited to and shall not exceed the costs of repair or replacement of defective parts. Snowex shall not be liable for loss of use, inconvenience or any other incidental, indirect or consequential damages, so the above limitations on incidental or consequential damages may not apply to you.

NO DEALER HAS AUTHORITY TO MAKE ANY REPRESENTATION OR PROMISE ON BEHALF OF TRYNEX INTERNATIONAL, OR TO ALTER OR MODIFY THE TERMS OR LIMITATIONS OF THIS WARRANTY IN ANY WAY.

Warranty Registration and Customer Survey



To initiate the warranty on your new SnowEx spreader and assure prompt warranty service, please complete the following warranty registration and customer survey, sign and mail it back to the factory within 30 days of purchase.

1) Date of Purchase: _____

2) Name: _____

Address: _____

Phone: _____

3) SnowEx Model Purchased: _____ Serial Number: _____

4) Is this your first Trynex Spreader? Yes No

5) What type of vehicle are you using with your Spreader?

Make _____ Model _____ Year _____

6) What type of material are you using in your spreader? _____

7) SnowEx Dealer Name: _____

SnowEx Dealer Address: _____

SnowEx Dealer Phone: _____

8) Does your Trynex Dealer stock Trynex replacement Parts? Yes No I don't know

9) Do you feel your Trynex Dealer sold you the correct product for your needs/application? Yes No

10) How would you rate your overall satisfaction with your SnowEx Dealer? Very Satisfied Satisfied Somewhat Satisfied Somewhat Dissatisfied Dissatisfied Very Dissatisfied

11) How would you rate your overall satisfaction with your SnowEx Product? Very Satisfied Satisfied Somewhat Satisfied Somewhat Dissatisfied Dissatisfied Very Dissatisfied

12) Would you purchase another Trynex Product? Yes No

13) If you would like to receive E-Mail ALERTS for new products, bulletins or special promotions please supply address: _____

14) Please use the space below to convey your comments and/or suggestions.

NOTE: I have read the owner's manual and all safety precautions and I understand that this equipment could be dangerous if not operated with care and under the proper conditions.

15) Owner's signature: X _____

PLEASE FOLD AND SEAL WITH TRANSPARENT TAPE BEFORE MAILING.