



UNITED KINGDOM



WESSEX[®]

PRODUCT GUIDE
2020

When only the best will do...

 **WESSEX[®]**
INTERNATIONAL 

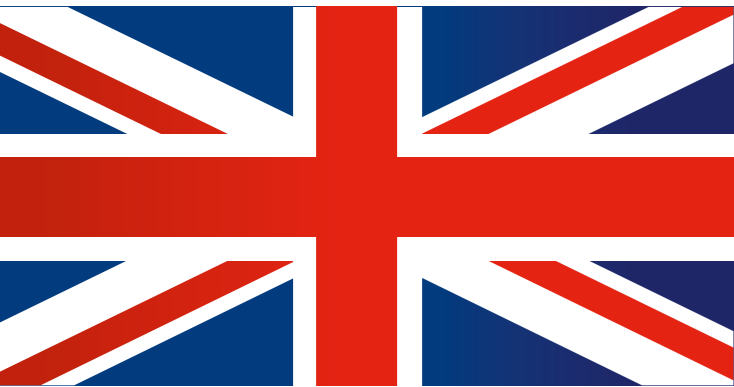

**MANUFACTURING
EXCELLENCE
SINCE 1962**

**SINCE 1962 THE WESSEX NAME HAS BEEN
SYNONYMOUS WITH SUPERB QUALITY,**

British built machines for the agricultural and groundcare markets. Our equipment is built for demanding applications, where reliability and durability are paramount.

WESSEX INTERNATIONAL'S global distribution network has distributors and dealerships in many countries. Whatever Wessex product you invest in, you can be sure of support from your local dealer right through the machines lifetime, backed by Wessex International's commitment to excellent customer service.

Our friendly and knowledgeable staff are here to advise you on the best equipment for your application. We are convinced you will find our machinery beneficial to your organisation both in terms of user satisfaction and economic ownership.



CHARLES BROWNING
Managing director

When only the best will do...



1962

In the heart of rural Hampshire, **WESSEX** began manufacturing grass cutting and forage equipment.



1970s

WESSEX were the first to manufacture a range of scaled down implements to suit the new compact tractor from Japan.



1980s

WESSEX increased their focus on equipment to meet the needs of landscapers and grounds maintenance contractors.



1990s

As ATVs started to grow in popularity, **WESSEX** produced a line-up of attachments to suit.



2003

Broadwood International was established as the distributor of quality equipment including the well-known **SNOWEX** salt spreaders & **SWEEPEX** push brooms.



2008

Broadwood International acquired **WESSEX MACHINERY** – now a leading manufacturer of professional grounds maintenance machinery.



2012

WESSEX celebrates **50 YEARS** of manufacturing and innovation



2014

In line with the increased focus on global distribution of the **WESSEX** product range, the company has been renamed **WESSEX INTERNATIONAL**. This coincides with relocation to the current 50,000sqft factory in Andover, Hampshire.



2018

WESSEX BFR-180 & **CROSSFIRE** straw spreader wins innovation of the year at LAMMA



2020

The introduction of **WESSEX POLARONE™** Salt and Grit Spreaders





Charlton House,
Caxton Close,
Andover,
SP10 3QN
United Kingdom

T: +44 (0)1264 345870

F: +44 (0)1264 345880

SALES

T: 01264 345870 (option 2)

E: sales@wessexintl.com

PARTS

T: 01264 345870 (option 1)

F: 01264 345880

E: parts@wessexintl.com

PRODUCT SUPPORT

T: 01264 345870 (option 2)

E: Ed.johnson@wessexintl.com

WARRANTY

T: 01264 345888

E: warrantyadmin@wessexintl.com

MARKETING TEAM

T: 01264 345870 (option 5)

E: marketing@wessexintl.com



MANUFACTURING EXCELLENCE SINCE 1962



ORDER YOUR WESSEX PARTS ONLINE NOW!

WHY SHOULD YOU TAKE THE PLUNGE?

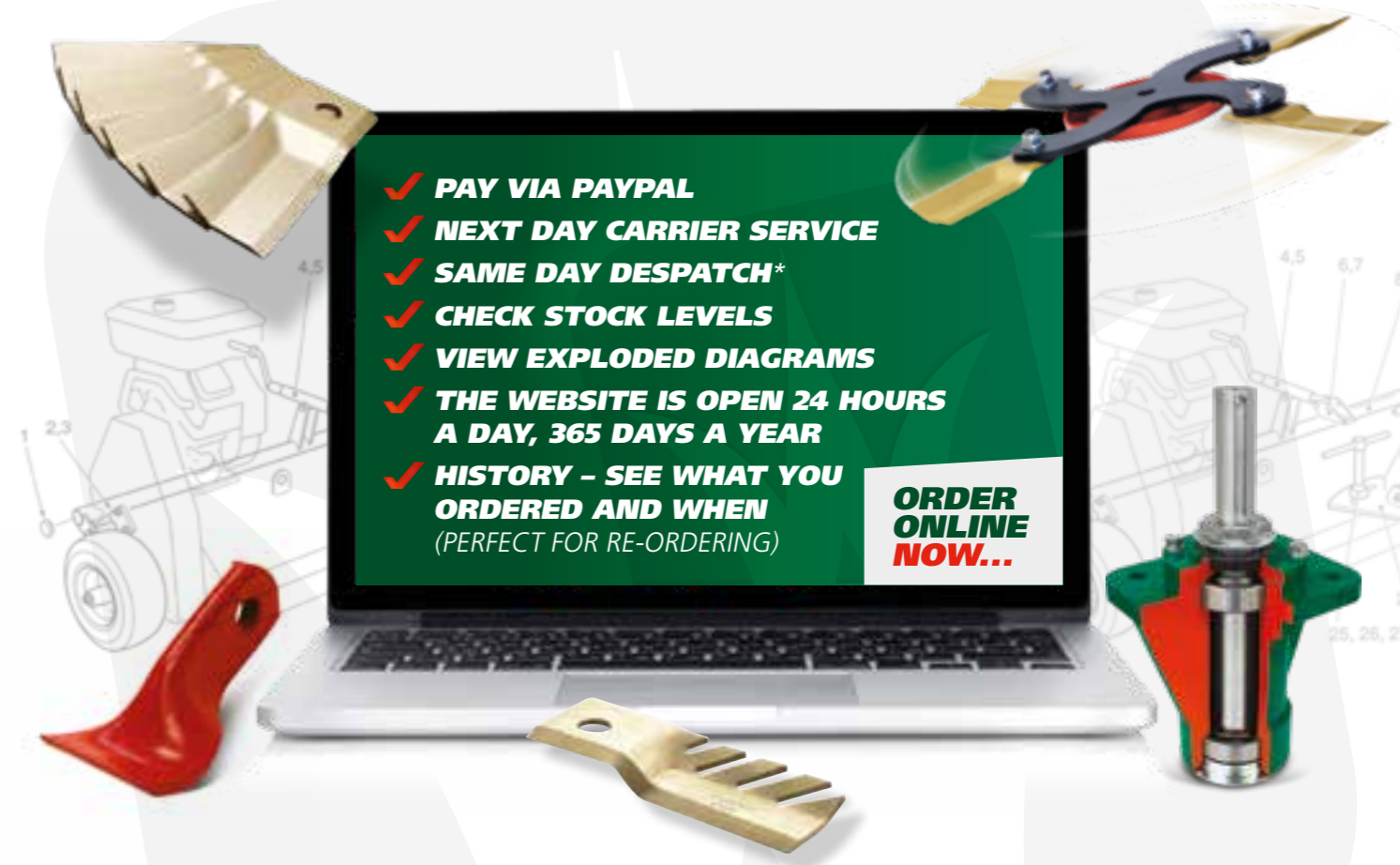

- ✓ **PAY VIA PAYPAL**
- ✓ **NEXT DAY CARRIER SERVICE**
- ✓ **SAME DAY DESPATCH***
- ✓ **CHECK STOCK LEVELS**
- ✓ **VIEW EXPLODED DIAGRAMS**
- ✓ **THE WEBSITE IS OPEN 24 HOURS A DAY, 365 DAYS A YEAR**
- ✓ **HISTORY - SEE WHAT YOU ORDERED AND WHEN (PERFECT FOR RE-ORDERING)**

ORDER ONLINE NOW...

GO TO **WWW.WESSEXINTL.COM/PARTS** TO ORDER YOURS **NOW!**

*See below for terms

WESSEX ARE SOCIAL:

Follow us on: #TEAMWESSEX for the latest news



SPARE PARTS

Only genuine Wessex spare parts should be used to maintain optimum performance from your Wessex machine. To minimise costly machine downtime, parts orders are dispatched daily to our professional dealer network by next-day carrier service (UK mainland), and 2 day for UK Highlands & Islands. If ordered before 1:00pm, parts will be dispatched the same day (subject to availability).

OUR ONLINE PARTS STORE IS OPEN 24 HOURS A DAY, 365 DAYS A YEAR.

Order your parts from your mobile or computer and we'll take care of the rest.

T: 01264 345878 **E:** parts@wessexintl.com





22 - 47

COUNTRYLINE RANGE

TRACTOR MOUNTED ATTACHMENTS FOR THE AGRICULTURAL, ESTATE & EQUESTRIAN MARKETS.



56 - 61

BALE FEEDING AND BEDDING



67 - 78

SNOWEX SNOW & ICE CONTROL



7 - 21

ATV EQUIPMENT

ATTACHMENTS FOR ATVs & UTVs



48 - 55

BROOMEX PUSH BROOMS



62 - 66

POLARONE™ PROFESSIONAL SALT & GRIT SPREADERS



79

WESSEX MERCHANDISE

2 YEAR WARRANTY

Selected products are available with a 2 year manufacturers warranty. These machines come with a standard one year warranty, and a further 1 year is available at no cost by simply completing an online registration via the website.

www.wessexintl.com/warranty-registration/



ATTACHMENTS FOR ATVs & UTVs

7 - 21

ROTARY MOWERS	8
AR-120, 1.2m, AR-150, 1.5m, AR-180, 1.8m	
PASTURE TOPPER	10
AT-110, 1.1m	
FLAIL MOWERS	12
AF-120, 1.2m, AF-160, 1.6m, AFE-120, 1.2m	
Paddock CLEANER	16
MTX-120-E, 1.2m	
SWEeper COLLECTOR	18
MTC-120-E, 1.2m	
FERTILISER SPREADER	19
FS-270-TP	
SPRAYERS	20
SS-604, SS-608P, SS-618P	
LAND ROLLER	21
LR-150, 1.5m	
ACCESSORIES	21
Ball Hitch	



When only the best will do...



The Wessex **AR SERIES ROTARY MOWERS** are the first choice for regularly mown areas, as the work rates are higher and the maintenance costs are lower than a flail mower. The **AR SERIES** includes 1.2m, 1.5m and 1.8m models with various engine options, and are well suited to general pasture topping or fine turf work and are popular on farms, studs and private estates.

SPECIFICATIONS

	AR-120	AR-150	AR-180
Cutting width	1.2m	1.5m	1.8m
Overall width/side wheels	1.7m	2.0m	2.3m
Cutting height range	25-140mm	25-140mm	25-140mm
Weight	218kg	241kg	329kg

ENGINE OPTIONS

Briggs & Stratton 12.5hp	✓	✓	-
Briggs & Stratton 13hp*	-	-	✓

*Electric start as standard with 13hp engine



KEY FEATURES & BENEFITS

- SMM DECK** – Shot-blasted and powder coated for durability
- SWIVELLING BALL HITCH** – Satisfies Health and Safety recommendations
- TURN BUCKLE ON THE DRAWBAR** – Levels the machine for an even cut
- DRAWBAR CAN BE OFFSET TO EITHER SIDE** – Cut outside of the quad wheelings
- THROTTLE LEVER** – Clips on to ATV rack for user convenience
- HEAVY DUTY BLADES WITH UPTURN ON TRAILING EDGE** – Durability and strong suction effect
- 16 X 6.50-8 TYRES**
- WHEELS IN-LINE WITH THE ROTORS** – Very well balanced, minimal weight on drawbar and excellent ground contour following
- FRICTION WELDED SPINDLES** – Run in heavy cast housings for maximum durability
- CHOICE OF BRIGGS & STRATTON ENGINE** – Powerful & reliable, 13hp with electric start as standard
- CENTRIFUGAL CLUTCH** – Allows the blades to be engaged / disengaged from the seat
- SIMPLE BELT ADJUSTMENT** – Both belts are tensioned simultaneously by one simple sliding action of the engine



When only the best will do...

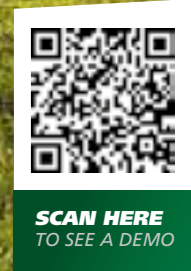

HEIGHT OF CUT IS SET BY REPOSITIONING THE WHEELS BY MEANS OF A SPRING LOADED PIN MECHANISM ON THE WHEEL BRACKETS

ALL MODELS FEATURE THREE OVERLAPPING ROTORS TO ELIMINATE UNCUT STRIPS OF GRASS, AND RIGID CUTTERBAR BLADES FOR DURABILITY

AVAILABLE WITH OPTIONAL REAR WHEEL KIT (AR-120 & AR-150 ONLY), IDEAL FOR MOWING CLOSE TO A FENCE



With the pedigree of the distinguished Wessex brand behind it, the Wessex **AT-110 TOPPER** will perfectly complement ATVs and utility vehicles in both groundcare and agricultural applications. Developed to suit the requirements of the ATV user working to a budget, the **AT-110** is an excellent blend of performance and value.

W SPECIFICATIONS

	AT-110
Cutting width	1.1m
Overall width	1.45m
Cutting height range	50-160mm
Weight	128kg
Engine	12.5 hp B&S

W KEY FEATURES & BENEFITS

- 1 STURDY DECK FABRICATION** – Shot-blasted and powder coated for durability
 - 2 12.5HP BRIGGS & STRATTON ENGINE** – Powerful, easy to start engine
 - 3 THROTTLE LEVER** – Clips on to ATV rack for user convenience
 - 4 DRAWBAR CAN BE OFFSET TO EITHER SIDE** – Cut outside of the quad wheelings
 - 5 ADJUSTABLE DRAWBAR** – Levels the machine for an even cut
 - 6 HEAVY DUTY BLADE GENERATES EXCELLENT MOMENTUM IN WORK** – Ideal for lush grass
 - 7 13 X 5.00-6 TYRES**
 - 8 SIMPLE HEIGHT ADJUSTMENT** – The AT-110 comes with a simple height-adjustment lifting device. This allows the operator to lift one side of the machine with their foot, leaving both hands free to reposition the wheels to the desired cutting height and secure with a pin.
- NS CENTRIFUGAL CLUTCH** – Allows the blade to be engaged / disengaged from the seat



SCAN HERE TO SEE A DEMO

SIMPLE HEIGHT ADJUSTMENT

OFFSET MOWING



The Wessex **AF SERIES FLAIL MOWERS**, in 1.2 and 1.6m working widths, have been developed to meet the needs of contractors, farmers and estate owners. They are well suited for controlling dense vegetation, i.e. brambles, bracken and long grass and for the maintenance of forestry and woodland areas.

TRIPLE BELT DRIVE FOR UNBEATABLE PERFORMANCE AND RELIABILITY!

The manual clutch and 3 high torque belts allows the Wessex **AF** flail mower to perform in arduous conditions without the inherent overheating problems associated with a centrifugal clutch.

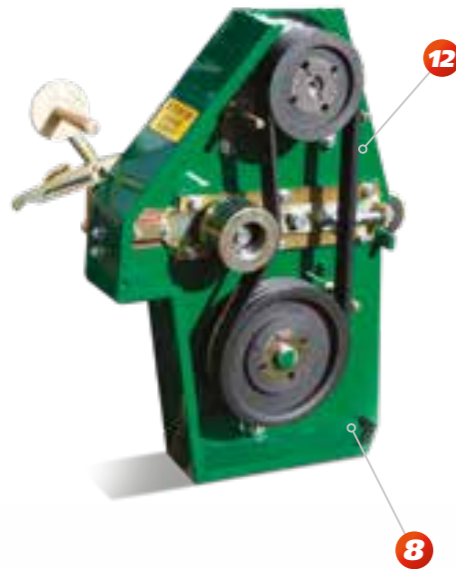

KEY FEATURES & BENEFITS

- 1 SMM DECK** – Shot-blasted and powder coated for durability
- 2 SWIVELLING BALL HITCH** – Satisfies Health and Safety recommendations
- 3 TURN BUCKLE ON THE DRAWBAR** – Levels the machine for an even cut
- 4 DRAWBAR CAN BE OFFSET TO EITHER SIDE** – Cut outside of the quad wheelings
- 5 KILL SWITCH CLIPS TO THE RACK OF THE ATV** – Emergency stop within easy reach of the operator
- 6 SCREW ADJUSTOR** – Simple height adjustment
- 7 POWERFUL 18HP V-TWIN ENGINE** – Ample power for demanding applications
- 8 MANUAL ENGAGEMENT CLUTCH** – Efficient power transmission without overheating
- 9 REAR ANTI-SCALP ROLLER** – Eliminates scalping in rough conditions
- 10 OPTIONAL HEAVY-DUTY FLAILS**
- 11 Y-PATTERN FLAILS** – Excellent mulching capabilities when cutting very long and dense vegetation
- 12 3 HIGH TORQUE BELTS** – Excellent power transmission
- 13 16 X 8.50-8 TYRES AS STANDARD FITMENT** – (22 x 11-8 flotation tyres as an option)
- 14 FRONT RUBBER FLAP** – Eliminates projectiles being thrown out in front of the machine



SCAN HERE TO SEE A DEMO





REAR WHEEL OPTION

Required if the machine is to cut close to fences and borders, or if the overall width is critical due to narrow access.

The rear wheel option is available on the 1.2m version. In this configuration significant weight is transferred onto the drawbar, therefore the user must check the drawbar capacity of the towing vehicle. When fitted with rear wheels, the **AF** has a screw jack on the drawbar to aid connecting to the towing vehicle.



FLOTATION TYRES

Machines with side wheels also have the option of 22 x 11-8 flotation tyres as an alternative to the standard grass tyres.

Ideal for working in boggy and low lying areas, the flotation tyres allow an ATV and a Wessex flail to operate in areas inaccessible to a tractor.



	AF-120	AF-160
Working width (m)	1.2m	1.6m
Overall width c/w side wheels	1.83m	2.23m
Overall width c/w rear/4 wheels	1.46m	1.86m
Cutting height range	10-160mm	10-160mm
Approx weight c/w side wheels	280kg	320kg



OFFSET MOWING



SCAN HERE TO SEE A DEMO

Boasting the same market leading quality and benefits as the flagship AF-120 model, the **AFE-120 FLAIL MOWER** has been designed for shredding and mulching long grass and vegetation in private ranches and grounds; and for less demanding professional applications.

	AFE-120
Working width (m)	1.2m
Overall width c/w side wheels	1.83m
Cutting height range	10-160mm
Approx weight	262kg
No. flails (pairs)	32

- KEY FEATURES & BENEFITS**
- ✓ **CENTRIFUGAL CLUTCH WITH TWIN BELTS** – Easy to use and great durability.
 - ✓ **SIMPLE CUTTING HEIGHT ADJUSTMENT** – Levels the machine for an even cut.
 - ✓ **13HP BRIGGS & STRATTON ENGINE** – Excellent power for demanding situations.
 - ✓ **5MM DECK** – Shot blasted and powder coated for durability.
 - ✓ **Y-PATTERN FLAILS** – Superb mulching capability in long vegetation.



REGULAR COLLECTION OF HORSE DROPPINGS IS ESSENTIAL FOR MAINTAINING A CLEAN AND HEALTHY Paddock ENVIRONMENT

The Wessex **DUNG BEETLE**, is a must for maintaining a healthy paddock and will not only collect horse muck, but also dead grass, leaves, twigs and other unsightly debris. The paddock will also benefit from the regular grooming action of the brush, which will stimulate growth of fresh, healthy grass – a benefit not gained from a vacuum machine.

POWERFUL SWEEPING

The rotor comprises four banks of hard wearing polypropylene bristles fastened into a hard plastic strip. The generous length of the bristles give a good “flick” action ensuring that any debris is propelled effortlessly into the hopper. The brush strips are simply bolted in pairs through the steel box section rotor, and are quick and easy to change when worn.

KEY FEATURES & BENEFITS

- 1 5.5HP ENGINE** – Easy to start and reliable
- 2 THROTTLE LEVER** – Clips on to ATV rack for user convenience
- 3 CENTRIFUGAL CLUTCH** – Allows the brush rotor to be engaged / disengaged from the seat
- 4 WHEELS IN-LINE WITH BRUSH ROTOR** – Follows ground contours accurately giving a consistent clean sweep
- 5 SIMPLE SCREW HANDLE** – Easy adjustment of brush height
- 6 FULLY CASTORING REAR WHEELS** – Increased manoeuvrability
- 7 FLOATING DRAWBAR** – Allows machine to float over uneven ground with no weight on ball hitch
- 8 ADJUSTABLE SPRING TINES** – Rake through the grass to loosen stubborn horse muck
- 9 HAND OPERATED WINCH** – For ease of emptying
- 10 STIFF, COURSE BRISTLE** – For increased sweeping efficiency in paddock environment
- 11 SWIVELLING BALL HITCH** – Satisfies Health and Safety recommendations

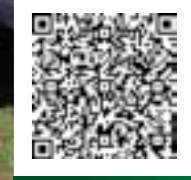

SCAN HERE TO SEE A DEMO

SPECIFICATIONS	
	DUNG BEETLE
Working width	1.2m
Overall width	1.85m
Hopper capacity	0.7m ³ (approx.)
Weight	317kg



SPRINGTIME SWEEPING WILL COLLECT DEAD GRASS, MOSS AND OTHER UNSIGHTLY DEBRIS PROMOTING FRESH SPRING GROWTH.

NO MUCK, NO WORMS HEALTHY HORSES



WESSEX MTC-120-E SWEEPER COLLECTOR



WESSEX FS-270-TP SPREADER



SPREAD LIMITER



EXTENDED AGITATOR



FILTERING GRID



SCAN HERE TO SEE A DEMO

Ideal for collecting autumn leaves, grass clippings and scarifying debris etc, the **MTC-120-E** is an effective sweeper that can be towed behind an ATV, utility vehicle, garden tractor or 4x4.

Designed for the maintenance of private estates, parks and large gardens, the **MTC-120-E** sweeper collector is based on the **DUNG BEETLE** paddock cleaner but is fitted with a softer bristle to eliminate scratching of sensitive turf.

FOR SPECIFICATIONS
SEE P12



When only the best will do...

The Wessex **TRAILED SPREADERS** are ideal for use behind ATVs and UTVs.

Available with a 270 litre poly hopper, this popular spreader will spread granular or powdered fertilisers or grass seed in a turf care application, game feed on estate or even dry granular salt for winter maintenance.

WESSEX SPECIFICATIONS

	FS-270-TP
Hopper Capacity (granular, fertiliser)	270 litres 345 kilos
Height	1.43m
Weight	84kg
Spread width	Up to 14m

WESSEX THE SALT SPREADER

VERSION INCLUDES THE FOLLOWING ADDITIONAL FEATURES:

- ✓ **SPREAD LIMITER** – Typically used in winter maintenance applications for spreading salt on pathways, the spread limiter restricts the application width to approximately 1.5m.
- ✓ **EXTENDED AGITATOR** – Keeps material moving within the hopper.
- ✓ **FILTERING GRID** – Breaks up lumps of salt before entering the hopper.



The Wessex ATV mounted **SS SPRAYER** range are packed with user-friendly features and benefits, and comprises a heavy-duty 55 litre rotomoulded tank and a choice of pump options to suit the width of boom required. All models come complete with 5m of hose and a hand lance for spot spraying.

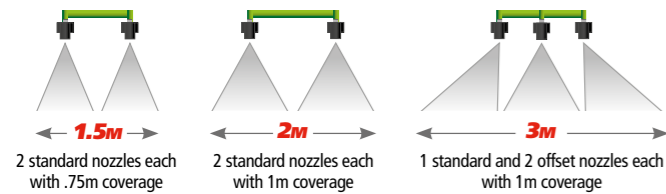

KEY FEATURES & BENEFITS

- 1 DURABLE ROTOMOULDED POLYETHYLENE TANK** – For maximum strength
 - 2 IN-LINE SUCTION FILTER** – Avoids pump contamination (SS-608-P & SS-618-P only)
 - 3 MOULDED HANDLES** – For ease of lifting
 - 4 OPTION OF 3 PUMP SIZES** – A machine for every application.
 - 5 PRESSURE CONTROL VALVE** – Maximum versatility (SS-608-P & SS-618-P only)
 - 6 HAND LANCE & 5M HOSE** – Ideal for spot spraying also allows spot spraying up to 5m away from the tank
 - 7 OPTION OF 5 BOOM SIZES** – A machine for every application
 - 8 HEIGHT ADJUSTABLE BOOMS**
 - 9 NOZZLE TAPS** – Turn off a nozzle to limit spray width
 - 10 ANTI-DRIP VALVES** – Avoid chemical leakage
 - 11 MOULDED HOSE WRAP** – Keeps hose securely coiled
 - 12 BRASS QUICK-RELEASE FITTINGS** – Easy change from boom to hand lance
- NS DRAIN PLUG AT LOWEST POINT** – Ease of emptying
- NS SUCTION HOSE DRAWS FLUID FROM THE LOWEST POINT** – Complete emptying
- NS BASKET FILTER STRAINS LIQUID AS TANK IS FILLED** – Clean water only enters the tank (SS-608-P & SS-618-P only. SS-604 has a gauze filter on the end of the suction hose)

SPECIFICATIONS

	SS-604	SS-608	SS-618
Approx full weight	57kg	60kg	60kg
Pump delivery (max ltr/min)	3.8	8	18
Max pressure	3 Bar	3 Bar	3 Bar
Boom options	1.5m	1.5, 2, 3m	1.5, 2, 3m

NO MORE BROKEN SPRAYER BOOMS!

All booms are kept within the width of the bike to avoid damage, and a combination of standard and off-set nozzles with anti-drip valves ensure an even spray of chemical up to 3m width. All booms are height adjustable.

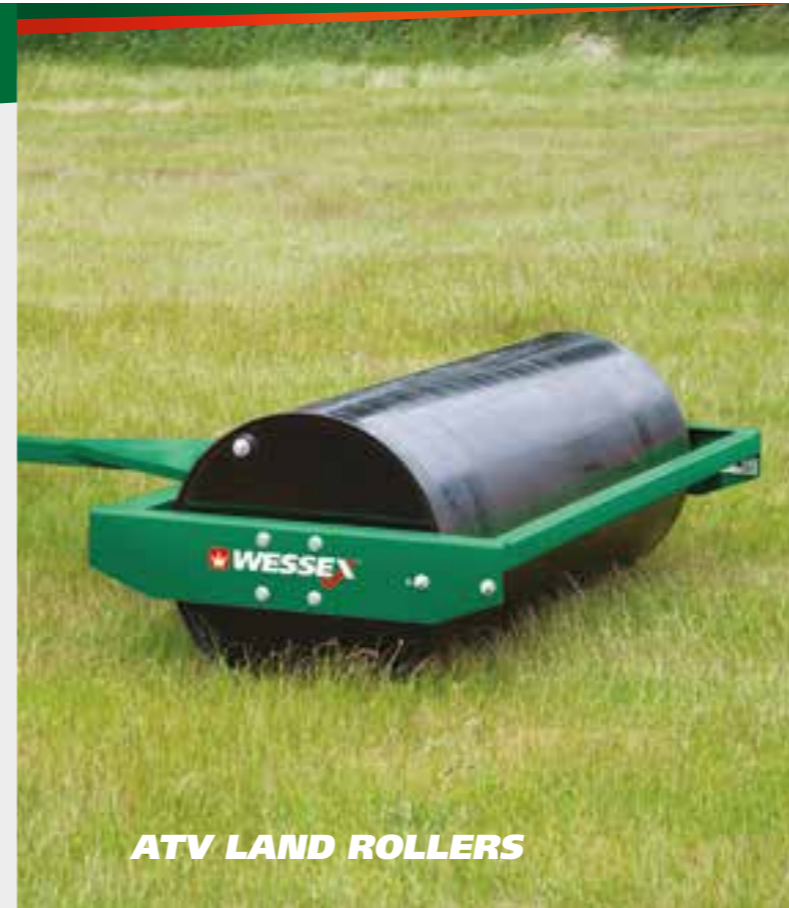

ATV LAND ROLLERS

WESSEX LAND ROLLER

A Wessex land roller is perfect for maintenance of lawns, paddocks and pitches.

Whether you tow them behind a compact tractor, a 4x4, or an ATV, Wessex land rollers will firm up the soil after a hard winter, and improve soil/root contact to enhance spring growth.

NEED MORE WEIGHT? NO PROBLEM - JUST ADD WATER!

The roller weighs up to 550kg when completely filled, and with a choice of clevis or ball hitch, you're ready to roll!

SPECIFICATIONS

	LR-150
Width	1.5m
Empty weight	200kg
Filled weight	550kg
Drum diameter	560mm

OTHER FEATURES

- Choice of ball or clevis hitch
- Adjustable scraper bar



ATV BALL HITCH

ATV ACCESSORIES

As manufacturers and distributors of one of the UK's largest range of professional ATV equipment we also offer accessories to make your ATV even more versatile and useful.

As with our ATV machinery, all our accessories are built to the highest standards without compromise, which in turn means you can have complete peace-of-mind when using and relying on these products, every day.

ATV BALL HITCHES

Simple, strong and easy to fit
Available in 19mm threads

When only the best will do...



COUNTRYLINE RANGE

TRACTOR MOUNTED ATTACHMENTS FOR THE AGRICULTURAL, ESTATE & EQUESTRIAN MARKETS.

22 – 47

FINISHING MOWERS

CMT-150, 1.5m, CMT-180, 1.8m, CMT-210, 2.1m

ROTARY SLASHER

SM-66, 1.7m

FLAIL MOWERS

WFM-115, 1.15m, WFM-145, 1.45m, WFM-175, 1.75m, WFM-220, 2.25m

OUT-FRONT FLAIL MOWERS

FRX-150, 1.50m, FRX-150-H, 1.50m

HEDGE CUTTERS

CHT-120, 1.2m

T-350-S, 3.6m, T-350-SI, 3.6m

T-320-A, 3.2m

T-380-D, 3.9m, T-430-D, 4.3m

T-500-G, 5m

23 TIPPING TRAILERS

T-125, 1.5ton, 1.5T-LGPW, 1.5ton, 3.0T-LGPW, 3.0ton

24 FERTILISER SPREADER

FS-360-P

25 ROTARY CULTIVATOR

RC-120, 1.2m, RC-150, 1.5m, RC-190, 1.9m

26 LOG SPLITTER

LS-100

28 SWEEPER COLLECTORS

MTX-120, 1.2m, MTC-120, 1.2m

30 PADDOCK CLEANER

STX-120 1.2m, STX-180, 1.8m

32 MULTIFUNCTIONAL COLLECTORS

34 STC-120 1.2m, STC-180, 1.8m

38

39

40

41

42

43

44

CMT SERIES FINISHING MOWERS



The Wessex **CMT SERIES FINISHING MOWERS** are an entry level range with superb build quality and great value for money. Available in 3 working widths, they are ideal for private estates and gardens.

3 overlapping rotors prevent unsightly uncut strips and the wheels are easily adjusted to the perfect cutting height. A perfect addition to any compact tractor.

SPECIFICATIONS

	CMT-150	CMT-180	CMT-210
Working width	1.5m	1.8m	2.10m
Overall width	1.63m	1.92m	2.25m
Cutting height range	19-110mm	19-110mm	19-110mm
Weight	226kg	251kg	300kg
Minimum power required	20hp	25hp	30hp
3-Point hitch type	Category 1	Category 1	Category 1
PTO Input speed	540	540	540
Number of blades	3	3	3

KEY FEATURES & BENEFITS

- ✓ **OVERLAPPING ROTORS** – No uncut strips of grass
- ✓ **ADJUSTABLE LOWER LINK POINTS** – Will suit any compact tractor
- ✓ **SIMPLE BELT ADJUSTMENT** – Ease of maintenance
- ✓ **FLOATING TOP LINK POINT** – Accurate ground contour following
- ✓ **SIMPLE CUTTING HEIGHT ADJUSTMENT** – Ease of operation
- ✓ **OPTIONAL MULCHING BLADES** – Lacerates clippings enhancing decomposition
- ✓ **ANTI-SCALP ROLLER** – to reduce scalping on undulating ground
- ✓ **STRONG BUILD QUALITY** – increasing product lifetime





WESSEX ARE STILL SUPPLYING PARTS FOR SCRUBMASTERS SOLD IN THE 1960'S!



In short, the Wessex **SCRUBMASTER ROTARY SLASHER** is unstoppable! Built to cope with the most arduous applications, this robust machine is ideal for controlling areas of dense vegetation and heavy scrubland ie, forestry plantations, firebreaks, rides, and gorse moorlands etc.

The massive blades will deliver over 3,000 1 ton impact cuts per minute making light work of brambles, gorse, heather and trees / saplings up to 100mm diameter. The chain cutters are recommended in areas where there are likely to be hidden rocks, boulders and tree stumps etc. The chains will thoroughly lacerate cut material, accelerating the breakdown and rotting process.

SPECIFICATIONS

	SM-66
Working width	1.7m
Overall width	1.8m
Blade tip speed	70.7 m/s
Weight (blades & chains)	516kg blades 468kg chains
Minimum power required	45hp

KEY FEATURES & BENEFITS

- ✓ **HEAVY-DUTY CONSTRUCTION** – Durability
- ✓ **MASSIVE GEARBOX** – Maximum drive transmission
- ✓ **FRICTION PLATE CLUTCH** – Overload protection
- ✓ **BLADE OR CHAIN CUTTERS ARE INTER-CHANGEABLE** – Varying applications
- ✓ **REPLACEABLE SKID SHOES** – Ease of maintenance
- ✓ **FLOATING HEADSTOCK** – Follows ground contours in rough areas
- ✓ **ADJUSTABLE SIDE SKIDS** – Simple height adjustment



SCAN HERE TO SEE A DEMO

For control of dense vegetation, long grass and woodland rides, the Wessex **WFM FLAIL MOWERS** are a real tough performer and are perfectly suited to the job. Hammer flails pulverise tough material while a full width adjustable rear roller maintains an even cutting height.

SPECIFICATIONS

	WFM-125*	WFM-145
Working width	1.25m	1.45m
Weight	160kg	385kg
Tractor horsepower	18hp	25hp
No. of hammers	18	18
No. of belts	3	4
Side shift	Manual	Hydraulic
	WFM-175	WFM-220
Working width	1.75m	2.25m
Weight	425kg	530kg
Tractor horsepower	40hp	60hp
No. of hammers	22	28
No. of belts	4	4
Side shift	Hydraulic	Hydraulic

These machines can be used in-line or offset, and are available to suit compact tractors from 18hp. The Wessex **WFM** flail mower is the machine of choice for the discerning smallholder!

KEY FEATURES & BENEFITS

- ✓ **FOR TRACTORS FROM 18HP TO 60HP**
- ✓ **MANUAL SIDES SHIFT** (WFM-125), **HYDRAULIC SIDE SHIFT** (WFM-145, WFM-175 & WFM-220)
- ✓ **CENTRAL GEARBOX EQUIPPED WITH FREE WHEEL CLUTCH**
- ✓ **FULL WIDTH ADJUSTABLE REAR ROLLER**
- ✓ **CE SAFETY CERTIFIED**
- ✓ **ADJUSTABLE SIDE SKIDS**
- ✓ **CAT 1, 3-PT HITCH**
- ✓ **SUPPLIED WITH HAMMER FLAILS**

Reduced budgets and less frequent mowing cycles mean that the local authorities require a machine that will cut and mulch lush grass without untidy swathing, as with a rotary mower. The Wessex **FRX-150/FRX-150-H** (hydraulic version) out-front flail mowers will do just that!



KEY FEATURES & BENEFITS

- 1 AERODYNAMIC FLAILS** – Minimum power consumption.
- 2 FULL WIDTH ANTI-SCALP ROLLER** – No unsightly scalping.
- 3 INTEGRAL ROLLER BEARINGS** – Protected for long service life.
- 4 SIMPLE AND POSITIVE HEIGHT ADJUSTMENT** – Ease of operation.
- 5 PUNCTURE PROOF TYRES** – Low maintenance.
- 6 TWIN DRIVE BELT TRANSMISSION** – Handles dense vegetation.
- 7 FULLY GUARDED TO HSE SPECIFICATIONS** – Meets local authority requirements.
- 8 CONTIFLOW DECK DESIGN** – Low profile deck design follows the path of the flails at a constant distance increasing the suction effect and improving mulching efficiency.
- 9 FLOATING LINKAGE** – Excellent ground contour following and a generous lift height which is ideal for curb clearance and trailer ramps etc.
- 10 WIDE OUTLET** – Maximum performance in long grass.
- 11 HARDENED STEEL STONE GUARDS** – Safety in public areas.
- 12 RIGHT ANGLE DRIVE GEARBOX OR HYDRAULIC MOTOR** – Smooth and quiet operation.
- 13 ROTOR BEARING GUARDS** – Protected for long service life.
- 14 ADJUSTABLE SIDE SKIDS WITH REMOVABLE WEAR-SHOES** – Low maintenance costs.

SPECIFICATIONS

	FRX-150	FRX-150-H
Cutting width	1.5m	1.5m
Overall width	1.73m	1.73m
Weight	220kg	212kg
Cutting height range	25-100mm	25-100mm
No. of flails	34	34



When only the best will do...



WILL SUIT MOST LEADING BRANDS OF POWER UNIT INCLUDING, JOHN DEERE, KUBOTA, SHIBAURA, NEW HOLLAND, RANSOMES, STIGA, ISEKI & TORO



SCAN HERE TO SEE A DEMO



The Wessex **CHT-120** 1.2m hedge cutter is perfect for trimming small trees, hedges and pruning edges, and are ideal for compact tractors of 15hp and above. The model features a 1.2m cutter bar and comes complete with cable controls. It is powered from the tractors hydraulics.

SPECIFICATIONS

	CHT-120
Cutter bar size	120cm
Vertical reach	410cm
Horizontal height	260cm
Horsepower required	15 - 40hp
Oil flow (L/min)	12
Weight	180kg
Minimum tractor weight	500kg

When only the best will do...



SCAN HERE
TO SEE A DEMO





MODEL SHOWN
T-350-S



MODEL SHOWN
T-350-SI



Designed for compact tractors, the **T-350-S** and **T-350-SI** are ideal for working in confined spaces. It is extremely versatile, has a 1.5m reach, and can work on both the left and right hand side of the tractor.

The **T-350-SI** has the features and benefits of the **T-350-S**, but with the added advantage of a hydraulic tank, pump and joystick controls.



CABLE CONTROLS
T-350-S



JOYSTICK CONTROLS
T-350-SI

KEY FEATURES & BENEFITS

- ✓ **REVERSIBLE, USE ON THE LEFT AND RIGHT OF THE TRACTOR**
- ✓ **3 POINT LINKAGE CAT 1 AND 2**
- ✓ **CABLE CONTROLS (CLASSIC) T-350-S.**
- ✓ **JOYSTICK CONTROLS T-350-SI**
- ✓ **ARMS WITH CIRCULAR SECTION H.T.R. (HIGH TORSION RESISTANCE) FOR STRENGTH.**
- ✓ **2X PARKING STANDS.**
- ✓ **ACCIDENT PREVENTION PROTECTIONS ACCORDING TO EC DIRECTIVES.**
- ✓ **CUTTER BAR WITH 32CC MOTOR**
- ✓ **FOR COMPACT TRACTORS FROM 15HP**

WORKING POSITIONS

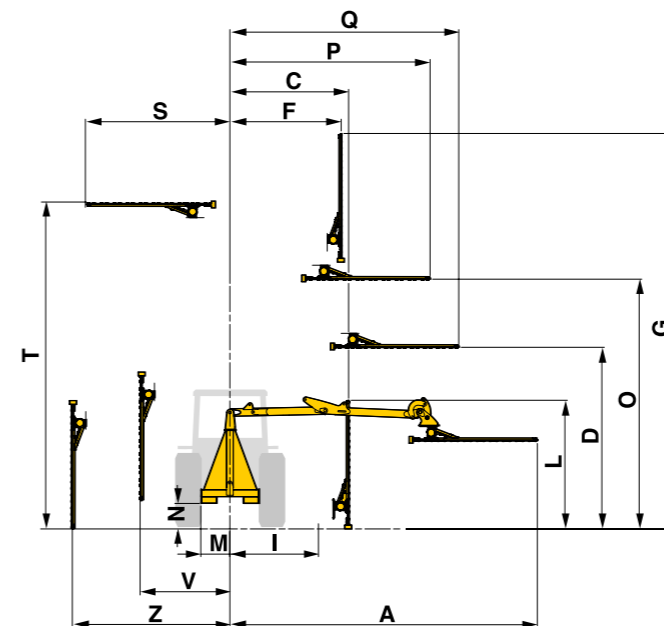

KEY

	T-350-S	T-350-SI	T-350-S	T-350-SI
A	3.62m	N	0.30m	
C	1.40m	O	2.94m	
D	2.14m	P	2.36m	
F	1.31m	Q	2.70m	
G	4.66m	S	1.72m	
I	1.10m	T	3.92m	
L	1.52m	V	1.26m	
M	0.35m	Z	2.02m	

SPECIFICATIONS

	T-350-S	T-350-SI
Cutting width	1.5m	1.5m
Max horizontal reach	4.6m	4.6m
Cutter bar head angle	228°	228°
Rotor speed	540rpm	540rpm
Weight	230kg	320kg
Tractor horsepower	15-50hp	25-50hp
Min tractor weight	700kg	900kg
Min tractor width	1m	1m
Category linkage	1&2	1&2



FLOATING HEAD ALLOWS THE MACHINE TO GIVE AN EVEN CUT OVER UNEVEN GROUND.



FRONT STEEL GUARDS ELIMINATES PROJECTILES BEING THROWN OUT IN WORK.



ADJUSTABLE REAR ROLLER - SIMPLE CUTTING HEIGHT SETTING.



TRACTOR STABILIZERS MAINTAIN RIGIDITY ON THE TRACTOR.



OPTIONAL CUTTER BAR, IDEAL FOR USE ON PUBLIC FOOTPATHS ETC.



MECHANICAL BREAKAWAY.

WORKING POSITIONS

The Wessex **T-320-A** hedgecutter is designed to suit compact tractors from 25hp.

Ideal for use on private estates, in large gardens, or on the public highways.

When only the best will do...

KEY FEATURES & BENEFITS

- ✓ **FLOATING FLAIL HEAD**
- ✓ **REVERSIBLE ROTOR**
- ✓ **Y FLAILS**
- ✓ **MECHANICAL BREAKAWAY**
- ✓ **FRONT GUARD ON FLAIL HEAD**
- ✓ **ADJUSTABLE REAR ROLLER**
- ✓ **CHOICE OF CABLE OR MONO-LEVER ELECTRIC CONTROLS**
- ✓ **OIL COOLER WITH THERMOSTAT**
- ✓ **FULLY INDEPENDENT HYDRAULICS**
- ✓ **MECHANICAL ROLL OVER PROTECTION SYSTEM**
- ✓ **FOR USE WITH TRACTORS FROM 25HP**



CABLE CONTROLS
T-320-A



JOYSTICK CONTROLS
T-320-AE



Y-PATTERN FLAILS ARE FITTED AS STANDARD.

KEY

	T-320-A		T-320-A
A	3.22m	G	1.60m
B	1.84m	H	2.76m
C	0.93m	I	1.10m
D	2.05m	M	0.62m
E	3.61m	N	0.30m
F	1.10m		

SPECIFICATIONS

	T-320-A
Cutting width	0.8m
Number of flails	32 Y-pattern
Max horizontal reach	3.22m
Flail head angle	190°
Rotor speed	3,200rpm
Blade tip speed	48m/sec
Max motor power	29hp
Max power to the rotor	20hp
Oil tank capacity	60L
Weight	370kg
Tractor horsepower	25-40hp
Min tractor weight	900kg
Min tractor width	1.2m
Category linkage	1 & 2

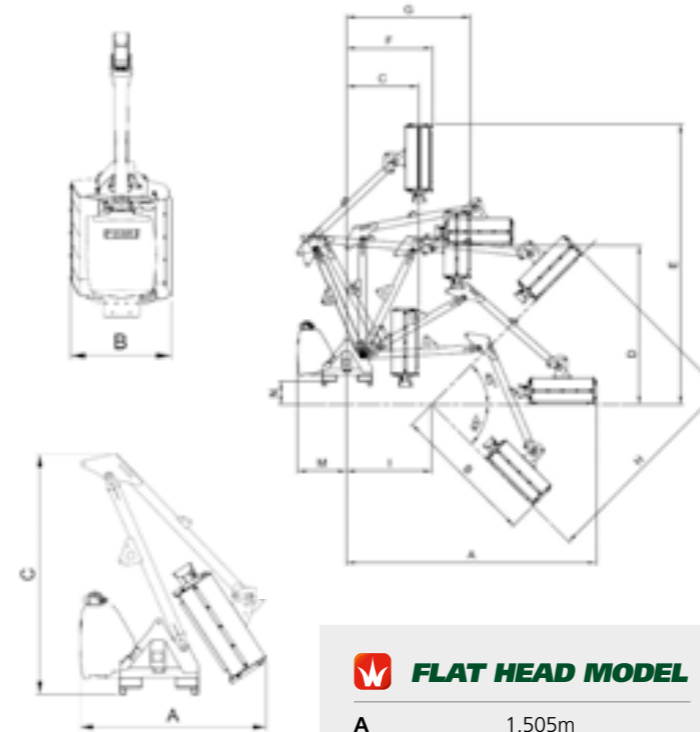

FLAT HEAD MODEL

A	1.505m
B	0.695m
C	1.94m

MACHINE AVAILABLE WITH REAR OR TOP MOUNTED CUTTING HEADS

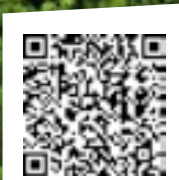

SCAN HERE TO SEE A DEMO

KEY FEATURES & BENEFITS

- ✓ **DELTA BOX FRAME** – For maximum strength
- ✓ **CHOICE OF CABLE OR MONO-LEVER ELECTRIC CONTROLS**
- ✓ **UNIQUE ROUND, TUBULAR ARMS** – For maximum torsional strength HTR (High Torsion Resistant)
- ✓ **DROP FORGED ARM LINKAGES**
- ✓ **FLOATING FLAIL HEAD**
- ✓ **CHOICE OF 2 FLAIL TYPES**
- ✓ **DURABLE POLYPROPYLENE HYDRAULIC OIL TANK**
- ✓ **FRONT & REAR HEAD PROTECTION GUARDS**
- ✓ **MECHANICAL BREAKAWAY**
- ✓ **FULLY INDEPENDENT HYDRAULICS**
- ✓ **OPTIONAL OIL COOLER WITH THERMOSTAT**
- ✓ **ADJUSTABLE ROLLER**
- ✓ **REVERSIBLE ROTOR**
- ✓ **MECHANIC ROLL OVER PROTECTION SYSTEM (SAB)**
- ✓ **OIL AND PTO SHAFT**
- ✓ **OPTIONAL LIFT FLOAT**



CABLE CONTROLS



MONO LEVER ELECTRIC CONTROLS



OPTIONS



THE POLYPROPYLENE OIL TANK IS SEPARATED FROM THE FRAME WHICH ALLOWS IT TO BE ISOLATED FROM ANY STRUCTURAL STRESS. FULLY RECYCLABLE.



OIL COOLER WITH THERMOSTAT.



OPTIONAL LIFT FLOAT ACCUMULATOR ALLOWS SMOOTH OPERATION WITH REDUCED BOUNCE ON THE ARM.



CIRCULAR SECTION OF THE ARMS H.T.R. (HIGH TORSION RESISTANCE).

FLAIL BLADE OPTIONS



1 Y-PATTERN FLAILS ARE FITTED AS STANDARD.



2 BOOTIE FLAILS

WORKING POSITIONS

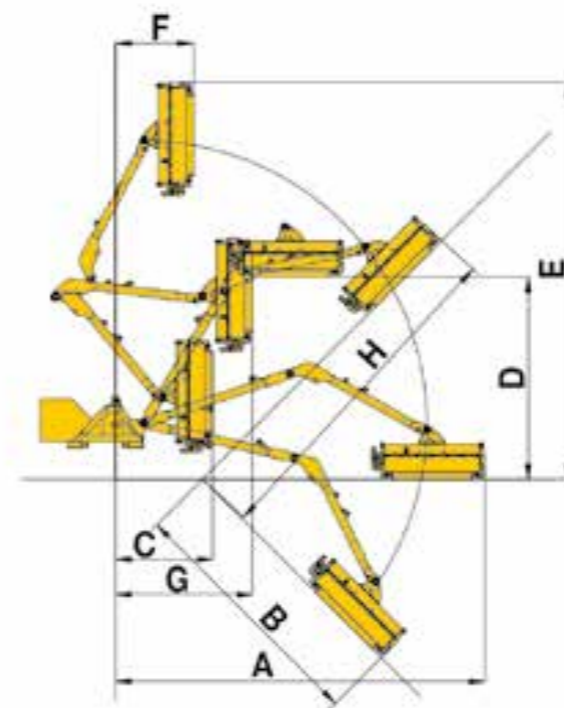

KEY

	T-380-D	T-430-D		T-380D	T-430-D
A	3.9m	4.4m	G	1.5m	1.65m
B	2.5m	2.96m	H	3.44m	3.95m
C	-	-	I	1.1m	1.1m
D	3.03m	3.5m	M	0.7m	0.7m
E	4.3m	4.8m	N	0.4m	0.4m
F	0.73m	0.73m			

SPECIFICATIONS

	T-380-D	T-430-D
Cutting width	1m	1m
Max horizontal reach	3.9m	4.4m
Flail head angle	235°	235°
Rotor speed	3000rpm	3000rpm
Blade tip speed	60m/sec	60m/sec
Max motor power	31hp	31hp
Max power to the rotor	20hp	20hp
Oil tank capacity	70L	70L
Weight	490kg	495kg
Tractor horsepower	40-60hp	50-70hp
Min tractor weight	1700kg	2000kg
Min tractor width	1.5m	1.7m
Category linkage	1&2	1&2

WESSEX T-500-G HEDGE CUTTERS

The **T-500-G** is the flagship model of the Wessex hedge cutting range. Featuring a 1.2m working width head with the option of various flail types for different applications.

The **T-500-G** has a reach of 5.0m and features a parallel arm for ease of operation. The machine offers the option of cable controls or the EP-Tronic proportional control joystick for accurate manoeuvrability.



CABLE CONTROLS



ELECTRIC-HYDRAULIC PROPORTIONAL CONTROLS WITH THE ACTIVATION OF THE ROTOR FROM THE CONSOLE

KEY FEATURES & BENEFITS

- ✓ **FLOATING FLAIL HEAD**
- ✓ **CHOICE OF CABLE CONTROLS OR PROPORTIONAL JOYSTICK**
- ✓ **CHOICE OF FLAIL TYPES 1-3**
- ✓ **PARALLEL ARM**
- ✓ **DURABLE POLYPROPYLENE HYDRAULIC OIL TANK**
- ✓ **90° POWER SLEW**
- ✓ **FRONT & REAR HEAD PROTECTION GUARDS**
- ✓ **ADJUSTABLE ROLLER**
- ✓ **FULLY INDEPENDENT HYDRAULICS**
- ✓ **REVERSIBLE ROTOR (DSR)**
- ✓ **MECHANICAL ROLLOVER PROTECTION (SAB)**
- ✓ **HYDRAULIC BREAKAWAY**
- ✓ **OPTIONAL LIFT FLOAT FOR FIRST ARM**
- ✓ **OPTIONAL OIL COOLER WITH THERMOSTAT**
- ✓ **OIL AND PTO SHAFT**

WORKING POSITIONS

KEY

- A 5m
- B 3.06m
- C 1.46m
- D 3.62m
- E 4.84m
- F 2.15m
- G 1.69m
- H 4.77m
- I 3.72m
- M 0.88m
- N 0.5m

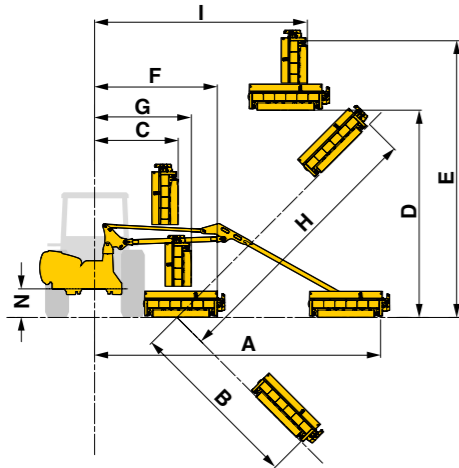

SPECIFICATIONS

	T-500-G
Cutting width	1.2m
Max horizontal reach	5m
Flail head angle	235°
Rotor speed	3100rpm
Blade tip speed	60m/sec
Max motor power	44hp
Max power to the rotor	34hp
Oil tank capacity	120L
Weight	860kg
Tractor horsepower	50-80hp
Min tractor weight	2800kg
Min tractor width	1.9m
Category linkage	2

FLAIL BLADE OPTIONS

- 1 STANDARD 'Y' PATTERN FLAIL
- 2 SPOON FLAIL
- 3 'T' PATTERN FLAIL
- 4 ARTICULATED 'Y' PATTERN FLAIL
- 5 BOOTIE FLAIL
- 6 HEDGE TRIMMING FLAIL



THE DYNAMICALLY BALANCED ROTOR HAS THE BLADES SITUATED IN A SPIRAL PATTERN FOR SMOOTH OPERATION.



When only the best will do...



SCAN HERE TO SEE A DEMO





Wessex **HYDRAULIC TIPPING TRAILERS** are available in 3 sizes; 1.25 ton, 1.5 ton & 3 ton gross weights. Aimed at the private estate, hobby farmer, groundscape & golf course applications, these popular trailers are ideal for hauling a variety of materials.

The optional weld-mesh extension sides are available on all models and will increase the carrying capacity when transporting bulky materials i.e. grass clippings and leaves etc.

KEY FEATURES & BENEFITS

- ✓ **ALL-STEEL CONSTRUCTION** – Durability
- ✓ **REMOVABLE SIDES** – Versatility
- ✓ **HINGED TAILGATE** – Ease of emptying
- ✓ **TURF TYRES** – Minimal turf compaction
- ✓ **OPTIONAL EXTENSION SIDES** – Increased carrying capacity
- ✓ **OPTIONAL LIGHTING KIT** – Be seen in the dark!

SPECIFICATIONS

	T-125	1.5T-LGPW
Bed length	1.9m	2.1m
Bed width	1.1m	1.2m
Overall length	2.7m	3.14m
Side height	0.35m	0.38m
Bed height	0.6m	0.65m
Weight capacity (ton gross)	1.25	1.5
Tyre size	20x8x10	23x10.5x12
Trailer weight	273.5kg	342.5kg
	3.0T-LGPW	
Bed length	2.5m	
Bed width	1.5m	
Overall length	3.55m	
Side height	0.39m	
Bed height	0.7m	
Weight capacity (ton gross)	3.0	
Tyre size	26x12x12	
Trailer weight	448.5kg	



The Wessex **FS-360-P** is a mounted spreader with a polypropylene non-corrosive hopper, and it's an excellent addition to any fleet of groundcare equipment.

Built to provide an economical yet extremely effective means of spreading fertiliser, seed, lime or dry salt this 360 litre capacity spreader simply connect to the tractor's 3 point hitch and PTO.

SPECIFICATIONS

	FS-360-P
Hopper Capacity	360 litres
Hopper Capacity kilos	466 kilos
Height	1.13m
Weight	63kg
Spread width	Up to 14m

KEY FEATURES & BENEFITS

- ✓ **360 LITRE CAPACITIES** – A machine for every application
- ✓ **STAINLESS STEEL DISC** – Resistance against corrosion
- ✓ **ADJUSTABLE FINS** – Alter spread pattern
- ✓ **OPTIONAL WINTER KIT** – Ideal for winter maintenance applications
- ✓ **WILL SPREAD A WIDE VARIETY OF MATERIALS**

When only the best will do...



Create the perfect seed bed or vegetable garden with a Wessex **LANDMASTER ROTARY CULTIVATOR**. Available in 1.2, 1.5 and 1.9m working widths, they are ideal for nurseries and glasshouses as well as private gardens, and boast features found on much more expensive models, such as slip clutch, adjustable tailgate and adjustable side depth skids.

Coupled to a compact tractor from 20hp+, the Wessex **LANDMASTER** rotary cultivator also meets all UK guarding regulations, for peace of mind.

KEY FEATURES & BENEFITS

- ✓ **HEAVY CAST GEARBOX**
- ✓ **CHAIN & SPROCKET DRIVE**
- ✓ **ADJUSTABLE SIDE SKIDS**
- ✓ **ADJUSTABLE TAILGATE**
- ✓ **CE CERTIFIED**
- ✓ **AVAILABLE IN 1.2, 1.5 AND 1.9M WORKING WIDTHS**

SPECIFICATIONS

	RC-120	RC-150	RC-190
Working width	1200mm	1500mm	1900mm
Overall width	1340mm	1645mm	2100mm
No. of blades	36	42	48
Weight	180kg	200kg	420kg
Minimum power required	20hp	25hp	45hp

The Wessex **LS100 LOGSPLITTER** turns a chore into an enjoyable task! With up to 10 ton of splitting force* at its disposal, the LS100 will effortlessly crack logs up to 18"/ 450mm in height.

A floor-level platform means loading logs onto the splitter is safe and easy, whilst two-handed operation keeps the operator protected.

SPECIFICATIONS

	LS-100
Weight	65kg
Height	1450mm
Width	850mm
Depth	590mm
Linkage	Cat 1
Pipe fittings	½ inch quick release probes
Minimum power required	30hp+

KEY FEATURES & BENEFITS

- ✓ **POWERFUL 10 TON SPLITTING FORCE** – Crack the toughest logs!
 - ✓ **2 HAND CONTROL** – Meets HSE requirements
 - ✓ **SIMPLISTIC DESIGN** – Easy to use
- * depending on tractor's hydraulic system

When only the best will do...



DOMESTIC AND COMMERCIAL HORSE OWNERS NEED TO KEEP PADDOCKS CLEAN, TIDY AND FREE OF DROPPINGS TO MAINTAIN A HEALTHY ENVIRONMENT FOR HORSES.



NO MUCK, NO WORMS HEALTHY HORSES

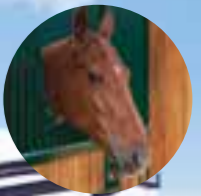

The Wessex **MTC/MTX TRAILED COLLECTORS** are available as a sweeper collector or a paddock cleaner in both PTO or engine driven versions for use behind a small tractor an ATV or UTV.

As a sweeper collector, the machine is fitted with supple bristles for turfcare applications. Grass clippings, autumn leaves and other debris will be flicked effortlessly into the hopper without damaging fine turf. The paddock cleaner version is fitted with a row of sprung steel tines in front of the rotor which loosens stubborn muck. The rotor is fitted with a heavy-duty bristle for maximum efficiency in a paddock environment. When full, the hopper is rolled over by means of a hand-operated winch to leave a clean discharge onto the ground.



With the **STX PADDOCK CLEANERS** in 1.2m or 1.8m widths, the chore of collecting horse muck is turned into a pleasure.

The strong and simple sweeping action of this machine will collect horse droppings, twigs and other debris into the hopper whilst the grass benefits from the regular grooming action of the bristles – an advantage not gained from vacuum machines. A powerful hydraulic ram tips debris from the hopper at a height of 1.3m into a low trailer or heap on the ground.



SPECIFICATIONS

	DUNG BEETLE
Working width	1.2m
Overall width	1.85m
Hopper capacity	0.7m ³ (approx.)
Weight	317kg

KEY FEATURES & BENEFITS

- ✓ **HARD WEARING POLYPROPYLENE BRISTLES** – Clean sweep every time.
- ✓ **BRUSHES EASILY REPLACEABLE** – Ease of maintenance
- ✓ **GROOM THE PADDOCK AS YOU SWEEP** – Generate new fresh grass
- ✓ **HYDRAULIC TIP** – Clean discharge

SPECIFICATIONS

	STX-120	STX-180
Working width	1.2m	1.8m
Overall width	1.6m	2.2m
Hopper capacity	1.5m ³	2.25m ³
Tipping height	1.3m	1.3m
Weight	530kg	645kg
Minimum power required	18hp	25hp

MULTI-FUNCTIONAL COLLECTORS

Available in 1.2m and 1.8m working widths, the **STC COLLECTOR** is a true, all-year-round machine for the maintenance of public parks, large amenity areas, sports turf and private estates.

Whether the requirement is for a flail collector to cut and collect on an out of season wild flower meadow, a professional scarifier for use on a sports pitch, or for a sweeper collector for clearing autumn leaves from areas of parkland, the **STC-120/180** is the ideal machine.

KEY FEATURES & BENEFITS

- ✓ **MULTIFUNCTIONAL** – Use one machine for sweeping, scarifying and flail mowing.
- ✓ **ALL YEAR ROUND MAINTENANCE MACHINE** – Reduced capital outlay.
- ✓ **LARGE CAPACITY HOPPER** – For improved workrates.
- ✓ **SEMI MOUNTED TO THE TRACTOR** – High capacity machine on a small tractor, reduces running costs.
- ✓ **HYDRAULIC TIP** – Ease of emptying.
- ✓ **WIDE TURF TYRES** – Minimal ground compaction.
- ✓ **ADJUSTABLE DRAWBAR** – Ideal for various size tractors.
- ✓ **RUNS ON ITS OWN FOUR WHEELS** – Follows ground contours accurately.
- ✓ **SIMPLE HEIGHT ADJUSTMENT** – Ease of operation.
- ✓ **PREMIUM POWDER-COAT PAINT FINISH** – Maximum durability.



ADJUSTABLE DRAWBAR



When only the best will do...

Mode 1

STC SWEEPER COLLECTOR

Collects autumn leaves and debris brilliantly.

When in sweeping mode, the **STC** is fitted with the brush rotor comprising 4 banks of hard-wearing polypropylene bristles which will lift autumn leaves, grass clippings and litter effortlessly into the hopper. The bristles, which are secured firmly into a pre-drilled strip with a wire staple, are a generous length to give a good 'flick' action ensuring that the material is thrown to the back of the hopper.



MODE CHANGE

Whatever mode the **STC** is purchased in, the option change kits allows the machine to be simply converted to perform the other 2 functions.

OPTION CHANGE KITS

FROM	TO	STC-120	STC-180
Scarifier	Flail mower (flails only)	OCK 3	OCK 10
Scarifier	Flail mower (rotor change)	OCK 6	OCK 13
Scarifier	Sweeper (flails only)	OCK 5	OCK 12
Flail mower	Scarifier	OCK 4	OCK 11
Flail mower	Scarifier (rotor change)	OCK 7	OCK 14
Flail mower	Sweeper	OCK 5	OCK 12
Sweeper	Scarifier	OCK 1	OCK 8
Sweeper	Flail mower	OCK 2	OCK 9

SPECIFICATIONS

	STC-120	STC-180
Working width	1.2m	1.8m
Overall width	1.6m	2.2m
Hopper capacity	1.5m ³	2.25m ³
Weight (in sweeper mode)	520kg	635kg
Power required	18hp	25hp

Mode 2

STC FLAIL COLLECTOR

Tackling long or short grass is no problem!

As a flail collector, the **STC** is fitted with a large diameter steel drum rotor with 4 rows of closely spaced flails, and 2 rows of draft paddles to create the suction for collecting the grass. The **STC** has no narrow throat as with many collectors, therefore long or short grass will be collected efficiently without blocking even in wet conditions.

Not only will the **STC** leave a fine finish on short turf, but is also ideal for end of season clearance of wild flower areas or golf course rough.

Mode 3

STC SCARIFIER COLLECTOR

Leaves sports turf at the top of it's game!

When in scarifying mode, the flail blades are replaced with 2mm verti-cutting knives for a professional scarifying operation. Ideal for sports field work or lawns, the **STC** scarifier will leave a clean cut through the turf at approx. 30mm centres and will collect the debris in one pass.



SCAN HERE
STC SWEEPING
LEAVES



SCAN HERE
STC FLAIL
COLLECTING



Mode 1

STC SWEEPER COLLECTOR



Mode 2

STC FLAIL COLLECTOR



Mode 3

STC SCARIFIER COLLECTOR



BROOMEX

PUSH BROOMS

48 – 55

BENEFITS OF A BROOMEX PUSH BROOM 49

BROOMEX C-BROOM 50
BM-150 MAX, BM-180 MAX, BM-240 MAX

BROOMEX BM PUSH BROOMS 52
BM-150, BM-180, BM-240

BROOMEX BP PUSH BROOMS 53
BP-150, BP-180, BP-240

BROOMEX APPLICATIONS 54



BENEFITS OF A BROOMEX PUSH BROOMS

The **UNIQUE MODULAR BRUSH SYSTEM** that is extremely efficient and economical for all commercial sweeping!

- ✓ **TACKLES BULKY MATERIALS**
- ✓ **WILL 'SQUEEGEE' WET SURFACES**
- ✓ **GENERATES MINIMAL DUST**
- ✓ **IS HIGHLY DURABLE**
- ✓ **SUPERB QUALITY**
- ✓ **IS THE EFFICIENT SWEEPING SOLUTION**
- ✓ **THE ORIGINAL AND THE BEST!**

WHY BROOMEX?

- ✓ **DO YOU WANT TO KEEP THE PREMISES TIDY?**
- ✓ **CONCERNED ABOUT HEALTH & SAFETY?**
- ✓ **DO YOU HAVE LIMITED FREE TIME?**

From building sites to farmyards the versatile **BROOMEX** sweeper system saves time and money. With no moving parts to increase the danger of flying debris, **BROOMEX** is safe and maintenance-free. Attach a **BROOMEX** brush quickly and simply to your host vehicle and off you go! A wide range of hitches enables **BROOMEX** to be attached to compact and large tractors, telehandlers, forklifts, loaders and skidsteers.

KEY FEATURES & BENEFITS

- ✓ **SWEEP UP TO 450 MILES BEFORE CHANGING THE BRISTLES** – Save time and money
- ✓ **A WIDE RANGE AVAILABLE** – A push broom to suit any sweeping application
- ✓ **UNIQUE PATENTED FEATURES** – A superior sweeping performance
- ✓ **A WIDE RANGE OF HITCHES** – Mount the BroomEx to the machine of your choice
- ✓ **NO MAINTENANCE REQUIRED** – Zero downtime
- ✓ **4MM HOOD THAT HAS BEEN SHOTBLASTED, UNDERCOATED AND POWDERCOATED** – Extremely robust
- ✓ **HARD WEARING POLY BRISTLES** – Longevity
- ✓ **NO STORAGE STAND REQUIRED** – Simple storage for when not in use
- ✓ **OPTIONAL MAGNETIC BARS** – No more punctures or injured livestock

THE RANGE



C-MAX SERIES

11 ROWS OF BRISTLES
Working widths: 2.4m, 1.8 and 1.5m



BM SERIES

11 ROWS OF BRISTLES
Working widths: 2.4m, 1.8 and 1.5m



BP SERIES

8 ROWS OF BRISTLES
Working widths: 2.4m, 1.8m, 1.5m

CHANGE THE BRISTLES WITH EASE



PLUS...

- ✓ **NO MOVING PARTS**
- ✓ **NO BELTS OF CHAINS**
- ✓ **NO MOTOR**
- ✓ **NO DOWNTIME**
- ✓ **NO PROBLEM**



**THE PUSH BROOM WITH
A TWIST – UP TO 65%
FASTER THAN A STANDARD
PUSH BROOM**



The innovative **BROOMEX 'C-MAX'** combines the well-known **BROOMEX** concept of a heavy duty push broom together with the patented side retainers, which will hold bulk volumes of material in front of the brush without spillage.

The end brushes are carefully twisted to pull material away from a curb or wall and into the main path of the broom. This ensures a clean sweep right into those awkward corners without the danger of the hood damaging the wall. Sweeping times will be reduced even further, as those frustrating spill lines will be eliminated with the new **BROOMEX 'C-MAX'**.

AVAILABLE HITCHES



C-MAX FORK SLEEVE HITCH



C-MAX FORK SLEEVE HITCH FOR 150MM FORKS



C-MAX 3 POINT LINKAGE HITCH



C-MAX TELEHANDLER QUICK HITCH

SPECIFICATIONS

	BM-150 C-MAX	BM-180 C-MAX	BM-240 C-MAX
Width	1.5m	1.8m	2.4m
Brush rows	11	11	11
Weight	117.5kg	132.5kg	166.5kg
Bristle height	280mm	280mm	280mm

When only the best will do...



**SCAN HERE
TO SEE A DEMO**





SCAN HERE
TO SEE A DEMO

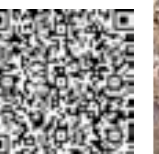

SCAN HERE
TO SEE A DEMO

BROOMEX BM PUSH BROOMS have 11 rows of bristles for maximum sweeping power in demanding applications. Ideal for use with full sized tractors and telehandlers.

Hitch options include fork sleeve hitch, three-point tractor hitch or custom hitches to suit any type of materials handler, loader or skidsteer. Available in 1.5m, 1.8m widths and 2.4m widths.

SPECIFICATIONS

	BM-150	BM-180	BM-240
Width	1.5m	1.8m	2.4m
Brush rows	11	11	11
Weight	94kg	109kg	143kg
Bristle height	280mm	280mm	280mm

AVAILABLE HITCHES



BM FORK SLEEVE HITCH



BM FORK SLEEVE HITCH FOR 150MM FORKS



BM 3 POINT LINKAGE HITCH



BM TELEHANDLER QUICK HITCH

BROOMEX BP with 8 rows of bristles, is ideal for counter-balance fork trucks and compact tractors.

An integral fork hitch is standard. Available in 1.5m and 1.8m widths.

SPECIFICATIONS

	BP-150	BP-180	BP-240
Width	1.5m	1.8m	2.4m
Brush rows	8	8	8
Weight	67kg	79kg	116kg
Bristle height	280mm	280mm	280mm

5 MEN SWEEPING FOR 1 HOUR OR 1 MAN SWEEPING FOR 5 MINUTES!

* COMPARISON BETWEEN USING MANUAL YARD BROOMS VS A BROOMEX

When only the best will do...

When only the best will do...



SNOW **CLEARANCE**



BUILDERS **MERCHANTS**



CONCRETE **PLANTS**



CONSTRUCTION **SITES**



GARDEN **CENTRES**



GOLF **COURSES**



GRAIN **STORES**



LANDSCAPE **MAINTENANCE**



LIVERY **YARDS**



LIVESTOCK **YARDS**



COMPOSTING **FACILITIES**



RECYCLING **CENTRES**



SAW **MILLS**



VEHICLE **BREAKERS**



WAREHOUSE & **DISTRIBUTION SITES**



SCAN HERE
TO SEE A DEMO





BALE FEEDERS & BEDDERS

56 – 61

THE RANGE	57
BFX-180 ROUND BALE FEEDER	58
BFR-180 MODULAR FEEDING & BEDDING SYSTEM	60



THE RANGE

BFX-180 ROUND BALE FEEDER

Designed to meet demand, the **BFX-180** is a simple to use, low maintenance round bale feeder that can be mounted to both tractors and telehandlers.



BFR-180 MODULAR FEEDING AND BEDDING SYSTEM

The **BFR-180** is a unique modular feeding and bedding system that can be supplied as:



SIDEWINDER
EXTENSION CONVEYOR

BFR-180
ROUND BALE FEEDER

CROSSFIRE
BEDDER ATTACHMENT

KEY FEATURES & BENEFITS

- ✓ **A ROUND BALE FEEDER** (BFR-180)
- ✓ **A ROUND BALE FEEDER WITH EXTENSION CONVEYOR** (BFR-180 & Sidewinder)
- ✓ **A ROUND BALE FEEDER AND STRAW BEDDER** (BFR-180 & Crossfire Bedder)
- ✓ **OR A COMBINATION OF ALL 3** (BFR-180, Sidewinder & Crossfire Bedder)

When only the best will do...

TRY IT FOR YOURSELF!
CALL US TO BOOK YOUR FREE DEMO TODAY!



Designed to meet demand, the simple to use, low maintenance **BFX-180** is a robust bale feeder loaded with the same features and benefits of the **BFR-180**.

It is ideal for livestock farmers who require a machine to feed out silage, hay, haylage or chopped material from either side with ease. Reduce time and manual labour with this versatile machine, and save up to 20% on feed bills through reducing wastage of feed.

WESSEX SPECIFICATIONS

Round bale size	BFX-180 up to 6'x5' (1.2m x1.2m or 1.8m x1.5m)
Round bale weight	up to 1000kg
Unit weight	525kg
Hydraulics required	1x double acting spool
Oil flow	12litres/min
CAT	2

3 STAGE LATCHING SYSTEM



- ✓ LIFT LATCH
- ✓ DRIVE BACKWARDS TO DISENGAGE HEADSTOCK
- ✓ SPIKE BALE

- ✓ PLACE BALE OVER CRADLE
- ✓ REMOVE WRAP
- ✓ LOWER BALE ONTO CRADLE

- ✓ LOCATE TINE CUPS
- ✓ DRIVE FORWARD TO ENGAGE HEADSTOCK
- ✓ HYDRAULIC DRIVE & SAFETY CATCH AUTO ENGAGES
- ✓ LIFT AND COMPLETE

WESSEX KEY FEATURES & BENEFITS

- ✓ **FEED ROUND BALES** – Save up to 20% on feed bills through reducing wastage of feed.
- ✓ **SAVE TIME AND MANUAL LABOUR** – Reduce time and remove the back-aching work of manually feeding.
- ✓ **FITS TO LOADERS & TRACTORS** – Very versatile to suit your current machinery. Comes standard with 3 point linkage. Optional Loader Brackets available.
- ✓ **NO ELECTRONICS** – Simple to use and maintain.
- ✓ **USE ON SMALLER LOADERS** – Designed specifically to mount on smaller loaders for agile yard work.
- ✓ **DETACHABLE LOADING HEADSTOCK WITH QUICKLATCH™ SYSTEM** – Fast and easy reloading without needing to unplug hydraulics.
- ✓ **FEED OUT FROM BOTH SIDES OF MACHINE** – Convenient to use.
- ✓ **HDPE (HIGH-DENSITY POLYETHYLENE) FEEDER FLOOR** – Tough material with zero corrosion minimising material leakage. Ideal for crumbly or wet bales.
- ✓ **STRONG BED CHAIN** – 5500kg load rated roller chains designed to handle the toughest of conditions.
- ✓ **STRONG CHAIN BARS** – Suitable for use with heavy silage bales.
- ✓ **LOW MAINTENANCE** – Only 2 grease points!
- ✓ **HIGH STRENGTH BOLT ON BALE SPIKES** – Great for use with tight bales.
- ✓ **OPTIONAL FRONT AND REAR CHAMBER PLATE** – A closed in chamber means you can handle loose feed such as root crops without leakage.
- ✓ **OPTIONAL OFFSET TRACTOR LINKAGE** – Drop the feed outside the width of the tractor making it easier to feed close to walls or into troughs.
- ✓ **OPTIONAL OFFSET LOADER BRACKETS** – Drop the feed outside the width of the loader meaning you won't drive over the feed. This also makes it easier to feed into troughs.

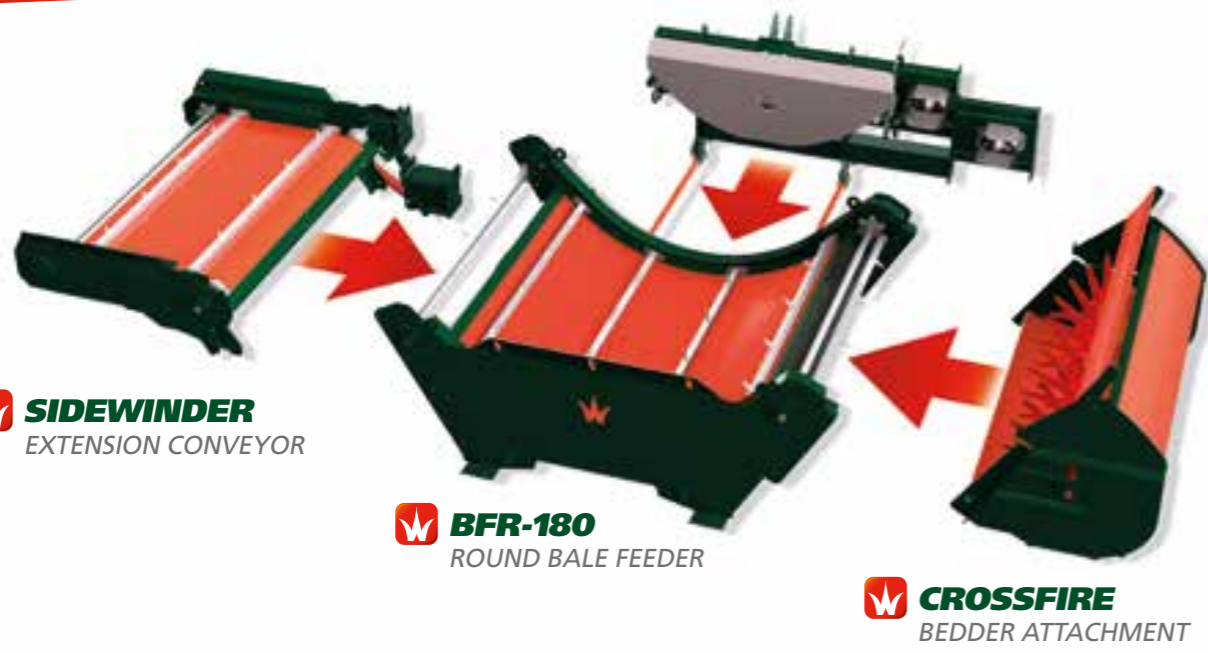

SIDEWINDER
EXTENSION CONVEYOR

BFR-180
ROUND BALE FEEDER

CROSSFIRE
BEDDER ATTACHMENT

KEY FEATURES & BENEFITS

- ✓ **FEED ROUND BALES** – Save up to 20% on feed bills
- ✓ **SPREADS WITHOUT CHOPPING** – Minimal dust and projectiles
- ✓ **UTILISE 1 MACHINE FOR 2 OPERATIONS** – Save time and money
- ✓ **BED UP TO 10 METRES** – Great bedding distribution
- ✓ **FITS TO LOADERS & TRACTORS** – Suits many applications
- ✓ **NO ELECTRONICS** – Simple to use and maintain detachable loading headstock
- ✓ **WITH QUICKLATCH™ SYSTEM** – Fast and easy reloading

SPECIFICATIONS

	BFR-180 & OPTIONS
Round bale size	Up to 6'x5' (1.2x1.2m or 1.8x1.5m)
Round bale weight	Up to 1,000kg
Unit weight (BFR-180 only)	770kg
Unit weight (with Crossfire only)	1,000kg
Unit weight (with Sidewinder only)	1,050kg est
Unit weight (with Crossfire & Sidewinder)	1,280kg est
Hydraulics required	1x double acting for BFR-180 & Crossfire, 2x double acting for Sidewinder
Oil flow	12 litres/min (BFR-180 only), 50 litres/min (Crossfire & Sidewinder)

3 STAGE LATCHING SYSTEM ... It's as simple as 1,2,3



- ✓ **LIFT LATCH**
- ✓ **DRIVE BACKWARDS TO DISENGAGE HEADSTOCK**
- ✓ **SPIKE BALE**

- ✓ **PLACE BALE OVER CRADLE**
- ✓ **REMOVE WRAP**
- ✓ **LOWER BALE ONTO CRADLE**

- ✓ **LOCATE TINE CUPS**
- ✓ **DRIVE FORWARD TO ENGAGE HEADSTOCK**
- ✓ **HYDRAULIC DRIVE AND SAFETY CATCH AUTO ENGAGES**
- ✓ **LIFT AND COMPLETE**

Designed and manufactured in our Hampshire UK factory, the Wessex **BFR-180** (patent pending) is a modular feeding and bedding system that can be configured as a bale feeder (**MODE 1**), a bale feeder with an extension chute (**MODE 3**), or a straw spreader and bale feeder combination (**MODE 2**).

The **BFR-180** only requires one tractor or telehandler to operate, and the maintenance is very low with only four grease points and no electrics!

VISIT THE WEBSITE OR CALL US TO BOOK YOUR DEMO TODAY.

BFR-180 ROUND BALE FEEDER

As a bale feeder, it can feed round bales of hay, haylage, straw and silage from either side with ease. Featuring massive 5,500kg rated roller chains with galvanized crossbars and a high spec Danfoss hydraulic motor, the **BFR-180** is a very reliable, seriously durable bale feeder that is simple to use and very easy to maintain.

- ✓ **REQUIRES ONE DOUBLE ACTING HYDRAULIC SPOOL**

BFR-180 ROUND BALE FEEDER & CROSSFIRE STRAW SPREADER

With the innovative **CROSSFIRE** straw spreader attached, bedding and feeding tasks can be undertaken with the same machine, bed from one side and feed off the other.

The Wessex **CROSSFIRE** straw spreader is unlike conventional straw choppers as it spreads the straw in its baled length, with minimal dust and projectiles, and up to ten metres. Straw choppers are renowned for creating excessive dust, which in an enclosed environment can be a serious threat to the health of the stock. Chopping bedding straw also reduces its effective life span within the bedding area.

- ✓ **REQUIRES ONE DOUBLE ACTING HYDRAULIC SPOOL**

BFR-180 ROUND BALE FEEDER & SIDEWINDER EXTENTION

The Wessex **SIDEWINDER** is an extension conveyor that attaches to the **BFR-180** for high level feeding into a trough or manger. The Sidewinder extends to the left leaving the right free to feed or alternatively bed with the **CROSSFIRE** straw spreader attached.

- ✓ **REQUIRES TWO DOUBLE ACTING HYDRAULIC SPOOLS, OR ONE DOUBLE ACTING WITH DIVERTER VALVE**

...OR A COMBINATION OF ALL 3 MODES

Feed into a trough or manger and bed straw with the same machine.

- ✓ **REQUIRES TWO DOUBLE ACTING HYDRAULIC SPOOLS, OR ONE DOUBLE ACTING WITH DIVERTER VALVE**





POLARONE™
PROFESSIONAL SALT & GRIT
SPREADERS

62 – 66

POLARONE™
PROFESSIONAL SALT & GRIT SPREADERS

62

WS-900 & WX-1200

66



SCAN HERE
TO SEE A DEMO



Welcome to **POLARONE™**, a market leading, low-maintenance range of salt and grit spreaders designed to withstand the harshest of winter conditions.

Manufactured at Wessex International's UK headquarters, the **POLARONE™ WS-900** and **WS-1200** are perfect machines to complement demanding winter maintenance programmes, as they can spread salt from their 900L and 1200L hoppers and liquid brine from the integral 465L tank simultaneously.

The optional **POLARONE™ COMMANDER** live tracking system, for fleet and productivity management, provides real-time spreading data and application rates, essential for precise application and minimal material wastage.

The **POLARONE™** vibration system is a patented auto vibration control to manage consistent material flow which is totally new and unique to the industry.

Constructed with a weight-saving polypropylene hopper, and stainless steel anti-corrosion components, **POLARONE™** is designed for longevity. **POLARONE™** can be trailer or vehicle-mounted and the list of key features and benefits is impressive.

SPECIFICATIONS

	WS-900	WS-1200
Hopper capacity - Level (Litres)	900	1200
Hopper capacity - Rounded (Litres)	1000	1320
Spread width	1.5-10m	1.5-10m
Integral brine tank vol (L)	465	550
Width (hopper only)	1140mm	1160mm
Height (hopper only)	1030mm	1030mm
Length (hopper only)	1820mm	2220mm
Bed length required	1750mm	2120mm
Auger diameter	105mm	105mm
Weight empty	210kg	230kg

When only the best will do...



When only the best will do...



MULTIFUNCTIONAL IN-CAB CONTROLLER, SPECIFY YOUR DESIRED APPLICATION RATE THEN LET THE CONTROLLER DO THE WORK!

The GPS connectivity will adjust material delivery according to your vehicle speeds to maintain a consistent application rate. A speed optimisation indicator will help you optimise your driving speeds to improve the accuracy of spreading and productivity of your equipment and reduce material wastage.

Activate **POLARFLO**™ auto vibration system to provide consistent material feed onto the spinner or switch to manual mode to individually control auger & spinner speeds & also vibrators.



ADJUSTABLE SPINNER HEIGHT AND FOLD UP FEATURE, FOR EASE OF STORAGE AND TO UTILIZE VEHICLE TOW HITCH

KEY FEATURES & BENEFITS

- 1 POLYPROPYLENE HOPPER AND INTEGRAL LIQUID TANK** with self-supporting design for durability & weight saving.
- 2 STAINLESS STEEL COMPONENTS & FIXINGS** for corrosion resistance and longevity
- 3 GPS CONTROLLED FLOW RATE FOR PRECISE APPLICATION** and minimal material wastage increasing profitability.
- 4 POLARFLO™ VIBRATION SYSTEM** – Patented auto vibrate control for consistent material flow
- 5 ADJUSTABLE SPINNER HEIGHT WITH FOLD UP FEATURE** – to suit a wide variety of vehicles
- 6 EXTENDED AUGER DESIGN** – allows better weight distribution in host vehicle
- 7 NO ENGINES, BELTS, CHAINS OR GREASE POINTS** – unique low maintenance design
- 8 ADJUSTABLE CHUTE FOR AN OFFSET SPREADING PATTERN**. Reducing the risk of overspread and increase output by treating two carriageways.
- 9 LARGE DIAMETER AUGER WITH DELIVERY TUNNEL** allows spreading of large range of materials, avoiding blockages and leakage.
- 10 CAN BE TRAILER OR VEHICLE BED MOUNTED**

- ✓ **AUTO OPERATION**
- ✓ **MINIMAL MATERIAL WASTAGE**
- ✓ **MAXIMUM PROFITS**



TRAILER
– OPTIONAL EXTRA



WIDE ANGLE AUGER
FOR HIGH VOLUME MATERIAL MOVEMENT



EMERGENCY STOP



POLARFLO™ VIBRATION SYSTEM
FOR CONSISTENT MATERIAL FLOW



MESH TOPSCREEN GRID
– PREVENTS LARGE CHUNKS ENTERING THE HOPPER



ALL WEATHER COVER
WITH STURDY FRAME FOR EASY UNCOVERING



SNOWEX RANGE 68 - 78

UTILITY SPREADERS	70
SP-575X-1, 163 L, SP-1575-1, 163 L, SP-1875-1, 254 L	
UTILITY SPREADERS MOUNTS	71
V-PRO SPREADERS	72
SP-2000, 300 L, SP-6000, 800 L	
HELIX SPREADERS	74
11780, 1100 L, 11790, 1700L	
SPREADER TECHNICAL SPECIFICATIONS	76
WESSEX WINTERLINE RANGE	78
SP-65, 47 L, BS-618, 55 L, FS-360-P-WK, 335 L, FS-270-TP-WK, 270L	

THREE OPTIONS ARE AVAILABLE:

1 MODEL ST

✓ A manually operated machine for those who want just a basic salt spreader, no speed control or data logging.

2 MODEL GT

✓ All the functions of the standard machine but with the addition of GPS speed control where the system monitors changes in FWD speed and spread widths to maintain the requested application rate.

3 COMMANDER

✓ All of the above with the addition of full telematics to provide a means to remotely monitor the salt spreader back at base. This set up would have access to a real time webpage and open up a variety of additional facilities such as route logging, reporting and ring-fencing machines.



OPTIONAL EXTRAS

- ✓ HIGHWAY TRAILER
- ✓ MOUNTING PLATE FOR NUMBER PLATE & LIGHTING BOARD
- ✓ BRINE, PRE-WET & SPRAY BAR
- ✓ WORK LIGHT



When only the best will do...

SNOWEX spreaders are the professional choice across the UK and Europe for efficient snow and ice control.

Designed and manufactured to perform in the harshest of environments, **SNOWEX** is built tough. In-cab control units provide precise operation of spinners and augers, combining quality with accuracy, and enabling operators to prevent overspreading and material wastage.

SNOWEX offers spreaders from 163 to 3200 litre capacity, and can be mounted on virtually any host vehicle from an ATV to large commercial vehicles. If you need help or advice on which **SNOWEX** spreader is best suited to your application just contact Wessex International and we will be happy to provide expert advice.

With increasing Health & Safety legislation making demands on ice and snow control, we can offer you peace of mind with a **SNOWEX** spreader.



TAMESIDE METROPOLITAN BOROUGH COUNCIL TAKE DELIVERY OF A V-MAXX SP-9500

SEE THEM IN ACTION ON:

KEY FEATURES & BENEFITS

ALL SNOWEX VEHICLE SPREADERS FEATURE:

- ✓ **12V DC DIRECT DRIVE MOTOR MOUNTED IN A WEATHER-TIGHT ENCLOSURE** – Reliable power in every situation
- ✓ **HIGH DENSITY POLYETHYLENE, UV PROTECTED HOPPER IN SAFETY YELLOW** – Zero corrosion and reduced weight
- ✓ **HEAVY DUTY MODULAR STEEL FRAME** – Strength built in as standard with electrostatic powder coat finish
- ✓ **DRIVES** – Revolutionary maximum torque transmission featuring a hardened steel worm and bronze gear - no chains, pulleys, drive belts or gears to break or wear
- ✓ **WEATHER AND FIRE-PROOF WIRING HARNESS** – for maximum reliability.
- ✓ **STEEL AUGER FEED SYSTEM** – gives more positive and accurate supply to spinner than a conveyor belt feed system
- ✓ **HIGH QUALITY POWDER COATED STEEL OR URETHANE SPINNERS**

FULL SPARE PARTS BACK-UP ON ALL SNOWEX PRODUCTS.



SCAN HERE TO SEE A DEMO



4x4's



PICK-UPS



TRUCKS



TRAILERS



TRACTORS



FORKLIFTS



ATVs



UTVs



PLUS, ANY VEHICLE THAT WILL TOW...



Three highly versatile **UTILITY SPREADERS**, which can be used in a variety of applications thanks to the wide range of mounting brackets available to suit commercial vehicles and 4x4's, utility vehicles, tractors, forklifts, or even a trailer mount for use behind an ATV.

BUILT TO WORK – WINTER AFTER WINTER!

UTILITY SPREADERS

SP-575X-1 – 163 LITRE

RAISING THE STANDARD IN UTILITY SPREADERS!

- ✓ **163 LITRE** capacity
- ✓ **ROBUST** all-weather cover
- ✓ **TOP SCREEN** prevents larger chunks from entering hopper
- ✓ **VARIABLE SPREAD** width controller
- ✓ **VERTICAL AUGER** feeds direct onto disc
- ✓ **VIBRATOR FITTED** as standard



SP-1575-1 – 163 LITRE

DESIGNED AND BUILT FOR THE CONTRACTOR!

- ✓ **163 LITRE** capacity
- ✓ **HORIZONTAL AUGER** and offset disc or increased efficiency and versatility
- ✓ **DUAL VARIABLE** speed/spread width controller
- ✓ **INTEGRAL 3PT MOUNTING HITCH** for compact tractors
- ✓ **VIBRATOR FITTED** as standard



SP-1875-1 – 254 LITRE

HIGH CAPACITY UTILITY SPREADER FOR LARGER VEHICLES!

- ✓ **254 LITRE** capacity
- ✓ **HORIZONTAL AUGER** and offset disc for increased efficiency and versatility
- ✓ **DUAL VARIABLE** speed/spread width controller
- ✓ **VIBRATOR FITTED** as standard



TRK FLOW RESTRICTOR TUBES

- ✓ Stainless steel flow restrictor tubes are available as an optional extra on the **SP-1575-1** and **SP-1875-1**, to prevent leakage of very free-flowing material.



SCAN HERE TO SEE A DEMO

TOWBAR HITCH TBH-175

Towbar hitch for commercial vehicles.



UTILITY MOUNT UTM-175

Utility bed-mount.



FORKLIFT MOUNT FLM-175

Industrial forklift mount.



THREE POINT HITCH TPM-175

3 point hitch for compact tractor (standard fitment on SP-1575-1).



DROP UTILITY MOUNT DRM-175

Drop utility mount reduces the height of the machine on the vehicle.



TRAILED MOUNT TLR-275

Trailer mount converts the SnowEx into a trailed machine for an ATV etc.



MOUNTS FOR UTILITY SPREADERS (FOR SP-1875-1 ONLY)

DROPSIDE MOUNT DSM-175

Attaches the SP-1875-1 to vehicle tailgate



FORK SLEEVE MOUNT FSM-175

Industrial forklift mount.



TRACTOR MOUNT TPM-275

Three point hitch for a compact tractor.



PICK-UP TRUCK HITCH PUH-175

Attaches to SP-1875-1 over the tail gate of a pick-up truck.

When only the best will do...

When only the best will do...

Two rugged **SNOWEX V-PRO** mounted spreaders which offer a revolutionary breakthrough in snow and ice control technology. With the hoppers entirely constructed of heavy duty polyethylene, **V-PRO** are considerably lighter than steel 'vee boxes'.

V-PRO SPREADERS CAN BE MOUNTED ON TO THE BESPOKE SNOWEX TRAILER; IDEAL FOR HIGHWAY SERVICE.

V-PRO SPREADERS

V-PRO SP-2000 – 300 LITRE

THE BULK SPREADER FOR HEAVY DUTY UTILITY VEHICLES!



- ✓ **300 LITRE** capacity
- ✓ **FULL CONTROL** of spread width and flow rate from comfort of vehicle cab
- ✓ **QUICK CONNECT** spinner assembly to allow towbar use when spreader not in service
- ✓ **DUAL VARIABLE** spread/speed controller for precise control of spinner and auger independently
- ✓ **12V VIBRATOR** unit to help material flow
- ✓ **HEAVY-DUTY** ratchet strap and adjustable rail mount system
- ✓ **FITTED** tarpaulin hopper cover

V-PRO SP-6000 – 800 LITRE

THE RUGGED SPREADER DESIGNED SPECIFICALLY FOR LARGER PICK-UPS AND FLAT-BED TRUCKS!



- ✓ **800 LITRE** capacity
- ✓ **FULL CONTROL** of spread width and flow rate from comfort of vehicle cab
- ✓ **QUICK CONNECT** spinner assembly to allow towbar use when spreader not in service
- ✓ **DUAL VARIABLE** spread/speed controller for precise control of spinner and auger independently
- ✓ **12V VIBRATOR** unit to help material flow
- ✓ **HEAVY-DUTY** ratchet strap and adjustable rail mount system
- ✓ **FITTED** tarpaulin hopper cover

OPTIONAL TRAILER VPT-150

- ✓ **FOR USE WITH SP-2000 & SP-6000**
- ✓ **IDEAL FOR WORK ON THE PUBLIC HIGHWAY** – full road legal specifications including lights, overrun brakes, suspension and hand brake
- ✓ **FREES UP THE PICK-UP** bed for other duties
- ✓ **RETAINS UNIQUE SNOWEX FEATURES** of on-the-move spread width and speed control - spreader loom extension included
- ✓ **READY TO HITCH UP** and go when required
- ✓ **NO VEHICLE TACHOGRAPH** normally required



FULLY ROAD LEGAL

SPREADING MATERIALS GUIDE

	SP-2000	SP-6000
Dry free-flowing salt	✓▲	✓▲
Moist salt (Rock salt)	✓	✓
Sand	✓*	✓
50:50 sand/salt mix	✓*	✓
Bagged ice melters	✓▲	✓▲

▲ if fitted with TRK kit * if fitted with OFK-020

Please note: this chart is a general guide and not all-inclusive. Wessex International will not be held responsible for spreader / spread material incompatibility.

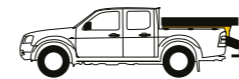

SP-2000



SP-2000 WITH VPT-150 TRAILER



SP-6000



SP-6000 WITH VPT-150 TRAILER



OPTIMUM FLOW KIT OFK-020

The optimum flow kit accessory is a requirement for spreading sand or a sand/salt mix. Along with a dual pitch baffle, the additional vibrator improves material flow of difficult-to-spread materials.



SCAN HERE TO SEE A DEMO

KEY FEATURES & BENEFITS

- 1 POLYETHYLENE HOPPER CONSTRUCTION**
 - ✓ Eliminates corrosion.
 - ✓ Is considerably lighter when compared to steel, making full use of the vehicle's payload.
 - ✓ Prolongs the life of the equipment.
- 2 PATENTED MULTI-ANGLED HOPPER**
 - ✓ Allows effective flow of material.
 - ✓ Spreads up to a 50/50 salt/sand mix with optional Optimal Flow Kit.
- 3 12-VOLT ELECTRIC DRIVE SYSTEM**
 - ✓ Offers low maintenance electric motor and drive, enclosed in single sealed unit.
 - ✓ Features only one grease fitting.
 - ✓ Requires no pulleys, sprockets, belts or chains.
- 4 INDEPENDENT SPINNER & AUGER CONTROL**
 - ✓ Controls spinner and auger independently for optimum material spread and feed.
 - ✓ Provides consistent positive feed of salt or salt/sand mixture.
 - ✓ Provides infinitely adjustable control with digital read-out.
 - ✓ Controls all functions from single controller, located inside the cab of the vehicle.
- 5 QUICK-CONNECT SPINNER ASSEMBLY**
 - ✓ Designed for easy installation and removal.
 - ✓ Allows use of towbar hitch when removed.
- 6 TOP SCREEN**
 - ✓ Prevents large frozen chunks of material from entering hopper.
- 7 FITTED TARP**
 - ✓ Provides protection from water ingress, for clog-free distribution of material.
- 8 NON-COMBUSTIBLE HD AUTOMOTIVE HARNESS**
 - ✓ Provides precise installation for risk-free wiring.

When only the best will do...

Available in 1,100 litres and 1,700 litres, the **SNOWEX HELIXX** spreaders have been built on the back of three decades of innovation. They are the spreader of choice for local authorities, highway maintenance contractors and commercial applications across the UK and Europe.

The **HELIXX** system has a patent-pending corkscrew auger delivery system, designed for efficient and cost-effective use of salt. The **HELIXX** auger runs the entire length of the hopper to promote the best possible material flow with even unloading and no clogging. Both models are complete with an in-cab dual variable-speed controller, for independent speed adjustment of the spinner and auger. Using this digital controller allows for precise material placement.

SPREADING MATERIALS GUIDE

	11780	11790
Dry free-flowing salt	✓*	✓
Moist salt (Rock salt)	✓	✓
Sand	✓	✓
50:50 sand/salt mix	✓	✓
Bagged ice melters	✓	✓

Please note: this chart is a general guide and not all-inclusive. Wessex International will not be held responsible for spreader / spread material incompatibility.

* Optional inverted-v and additional vibrator are recommended for materials that are susceptible to compacting



SCAN HERE
TO SEE A DEMO

HELIX 11780 & 11790 SPREADERS

HELIXX 11780 – 1,100 LITRE



- ✓ **1,145 LITRE** capacity hopper
- ✓ **FOR USE WITH COMMERCIAL VEHICLES** or mount on the optional VMT-250 trailer
- ✓ **SIMPLE CONNECTION** to the in-cab controller via a 4 pin cable

HELIXX 11790 – 1,700 LITRE



- ✓ As the 11790 but with larger **1,720 LITRE** capacity hopper
- ✓ **SIMPLE CONNECTION** to the in-cab controller via a 4 pin cable

OPTIONAL TRAILER VMT-250-2

- ✓ **FOR USE WITH HELIXX 11780 & 11790**
- ✓ **IDEAL FOR WORK ON THE PUBLIC HIGHWAY** – full road legal specifications including lights, overrun brakes, suspension and hand brake
- ✓ **FREES UP THE PICK-UP** bed for other duties

- ✓ **RETAINS UNIQUE SNOWEX FEATURES** of on-the-move spread width and speed control - spreader loom extension included
- ✓ **READY TO HITCH UP** and go when required
- ✓ **NO VEHICLE TACHOGRAPH** normally required



KEY FEATURES & BENEFITS

- 1 POLYETHYLENE HOPPER CONSTRUCTION**
 - ✓ Eliminates corrosion and enhances life of the equipment.
 - ✓ Is considerably lighter when compared to steel.
 - ✓ One-piece closed bottom unit.
- 2 PATENT PENDING HELIXX CORKSCREW AUGER DELIVER SYSTEM**
 - ✓ Full length auger for even unloading with no clogging
- 3 CAB FORWARD HOPPER**
 - ✓ Delivers better payload distribution to reduce stress on the truck.
- 4 STAINLESS STEEL FRAME**
 - ✓ Features a unique leg and sill design to form a ridged backbone structure for greater durability.
- 5 1/2 HORSEPOWER 12-VOLT ELECTRIC DRIVE SYSTEM**
 - ✓ Low maintenance, high-torque, commercial continuous-duty electric motor.
 - ✓ Weather-resistant sealed unit for durability.
 - ✓ Two grease fittings (Zirk fittings) for easy maintenance.
 - ✓ Drives a variable-pitch solid-shaft auger.
- 6 QUICK-CONNECT SPINNER ASSEMBLY WITH NO BLAST STARTUP**
 - ✓ Designed for easy installation and removal.
 - ✓ Allows use of towbar hitch when removed.
 - ✓ Features durable corrosion-resistant stainless steel.
 - ✓ For maximum material placement and control, the spinner doesn't blast upon startup, instead starting at the desired speed setting on the dial.
- 7 INDEPENDENT SPINNER & AUGER CONTROL**
 - ✓ Both models are complete with an in-cab dual variable-speed controller, for independent speed adjustment of the spinner & auger. Using this digital controller allows for precise material placement.
- 8 TOP SCREEN**
 - ✓ Prevents large frozen chunks of material from entering hopper.
 - ✓ Provided as standard equipment.
- 9 FITTED TARP**
 - ✓ Provides protection from water ingress, for clog-free distribution of material.
- 10 NON-COMBUSTIBLE HD AUTOMOTIVE HARNESS**
 - ✓ Only requires a single 4-pin wire routed into the cab to install the compact control.
- 11 WORK LIGHT**
 - ✓ Offers better visibility at rear of spreader during night applications.

PEDESTRIAN SALT SPREADER

SP-65 – 47 LITRE

- ✓ **IDEAL FOR** domestic or light industrial user
- ✓ **TOP SCREEN** to prevent larger chunks from entering hopper
- ✓ **ADJUSTABLE FLOW GATE**
- ✓ **FOR SPREADING** of free-flowing materials
- ✓ **47 LITRE** capacity
- ✓ **UP TO 6M** spread width



ATV LIQUID BRINE SPRAYER

BS-618 – 55 LITRE

- ✓ **WITH HAND LANCE & HOSE**
- ✓ **B-MNB** – Brine spraying boom, 1.50m.



GRANULAR SALT SPREADERS

All models c/w winter spreading kit and plastic hopper.

FS-360-P-WK – 335 LITRE
MOUNTED PTO SALT SPREADER

FS-270-TP-WK – 270 LITRE
– TRAILED SALT SPREADER

All FS salt spreaders are fitted with FS-WK winter kits.



**CALL US TO PLACE AN ORDER ON:
01264 345870**



BASEBALL CAP

One size fits all



GILLET

Available in; S, M, L, XL, XXL, XXXL



FLEECE-LINED JACKET

Available in; S, M, L, XL, XXL



WESSEX POLARONE BEANIE

One size fits all



WESSEX POLARONE ICE SCRAPER

Fits inside your wallet and made from recycled plastic



THERMAL MUG

400ml capacity mug

Items may vary from those listed above.



When only the best will do...



**MANUFACTURING
EXCELLENCE
SINCE 1962**

DEALER STAMP



WESSEX INTERNATIONAL Charlton House, Caxton Close, East Portway Ind. Est., Andover, Hampshire, SP10 3QN
T: 01264 345870 **F:** 01264 345880 **E:** sales@wessexintl.com **www.wessexintl.com** Follow us on:    

L526. © Wessex International 2020. E&OE. Specifications may change without notice. Wessex International is a trading name of Wessex International Machinery.

